



Car Park Swing Barrier

2.2M HIGH X 3.0M WIDE SWING BARRIER WITH HIGH LEVEL SWING ARM ONLY KIT	SWI-KIT-3050
2.2M HIGH X 4.0M WIDE EXTENDED SWING BARRIER WITH HIGH LEVEL SWING ARM ONLY KIT	SWI-KIT-3060
2.2M HIGH X 5.0M WIDE SWING BARRIER WITH HIGH LEVEL SWING ARM ONLY KIT	SWI-KIT-3070
2.2M HIGH X 6.0M WIDE EXTENDED SWING BARRIER WITH HIGH LEVEL SWING ARM ONLY KIT	SWI-KIT-3080

Operations, Maintenance & Installation Manual

Proudly Compliant with:



Proud to work with our partners



This manual provides a comprehensive overview for the installation, operation, and maintenance of the First Fence Car Park Swing Barrier product line. The range of four car park swing barriers have been specifically designed to provide a safe, controlled, and secure method of regulating vehicle access in car parks and restricted areas.

For safe operation, users should ensure the barrier is fully opened or closed before vehicle movement. Care should be taken to avoid rapid or uncontrolled movement during use.

Routine inspection and maintenance should be carried out to ensure continued safe operation. This includes checking hinges, pivot points, locking mechanisms, and fixings for wear, damage, or loosening. Any issues identified should be addressed promptly to maintain security, functionality, and longevity of the barrier system.

Disclaimer: This guide is for informational purposes only. The installer is responsible for ensuring the installation complies with all relevant British Standards, local building regulations, codes of practice, and site-specific risk assessments. While every attempt has been made to verify the accuracy of the content in this guide upon its release, we cannot accept liability for any losses or damages resulting from inaccuracies. All tasks outlined must be carried out by certified professionals. Any deviation from these instructions nullifies any guaranteed entitlement or liability from the manufacturer.

Copyright: The copyright of this guide is owned by First Fence Ltd and is protected at all times. Reproduction of this guide by any means is strictly prohibited without prior written consent from First Fence Ltd.

Contact: For enquiries regarding the installation, operation or contents of the guide in relation to this product please direct your questions to : The Product and Drawing Office Manager, First Fence Ltd, Off Kiln Way, Swadlincote, South Derbyshire DE11 8EA. Or The Product and Drawing Office Manager sales@firstfence.co.uk +44 1283 380054.

Manufacturer and/or Reseller: First Fence Ltd, Off Kiln Way, Swadlincote, South Derbyshire DE11 8EA. www.firstfence.co.uk +44 1283 380054.

Competence: This product must be installed by a person of competence, defined as an individual who possesses the necessary knowledge, skill and experience in the installation of fences and gates.

Liability: This installation guide should be understood and followed before any installation activities commence. If any area of the installation is unclear, the installer must contact the manufacturer, outlined in 'Contact.' First Fence Ltd takes no responsibility for incorrectly installed systems, product, material or components.

1.0 Safety & Tools

Personal Protective Equipment (PPE)

The following minimum PPE is required for installation:

Hard Hat
Must be worn



Eye Protection
Must be worn



Safety Gloves
For all material handling



Foot Protection
Must be worn



Risk Assessment

Installers are responsible for completing a site-specific risk assessment and complying with all local risk assessments before starting work. This responsibility includes, but isn't limited to, the following:

Activity	Risk Assessment Requirements and Not Limited to
Breaking ground for post hole excavations	Noise Vibration Manual Handling
Post Installation	Hazardous Substances (COSHH) Manual Handling
Installation of Fixings	Noise Vibration Working at Height

Tools & Equipment

Safety Gloves

Required for all material handling, any COSHH tasks including Post Mix, and any installation tasks.



Drill/Buzz Gun

For fixings installation



Shovel/Excavation

Required for excavation of holes to suit post foundations



Spirit Level

For plumb (vertical) and level installation



Time

Required for Post Mix curing or patched fixing curing



Cable Avoidance Tool

To identify hidden services embedded in the wall



2.0 Pre-Installation

Underground Services

Before any drilling, establish and mark the locations of all services within the working area (e.g., electrical conduits, water pipes). Use a Cable Avoidance Tool (CAT) and refer to building plans where available to prevent damage to services.

Materials Check

Unpack the kit and verify all components are present and undamaged, checking against the Bill of Materials (Section 4.0). Ensure all components are free from excessive corrosion or damage.

Site Preparation For Car Park Swing Barrier

Note: Barriers should be installed so that, when opened, they do not obstruct traffic routes, pedestrian walkways, or designated access/egress points. The swing path must remain clear of kerbs, structures, and any other fixed obstacles to prevent damage or unsafe operation.

Note: Barrier Installation Clearing

1	Before beginning installation, coordinate with a site manager if needed. Ensure the ground is cleared and prepared for installation.
	
	

Note: Clearance Gap

2	Standard outside-to-outside post widths vary depending on specific size bought, but always verify on-site. Accurate levelling is critical.
	
	



Note: Not adhering to the level ground tolerance may result in your system not fitting correctly, or may result in misalignment!



Note: Ground Level

Carpark swing barriers require level ground across their entire opening arc for safe and consistent operation. Installing on a slope or uneven surface causes fluctuating ground clearances beneath the barrier. This can cause the barrier to 'ground out' or scrape against the tarmac, creating physical resistance that prevents the mechanism from fully opening for vehicles or completely shutting to secure the carpark.

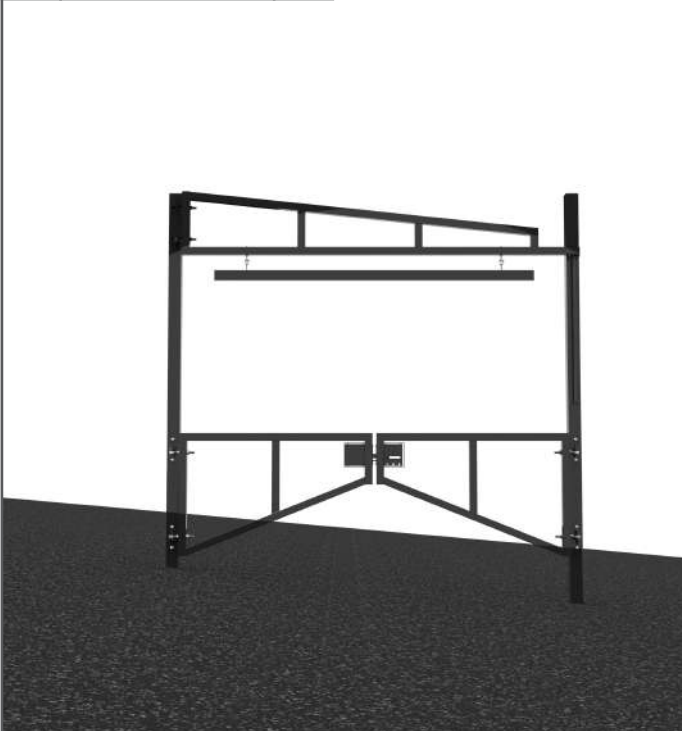
4a	Bad Practice	✘
		

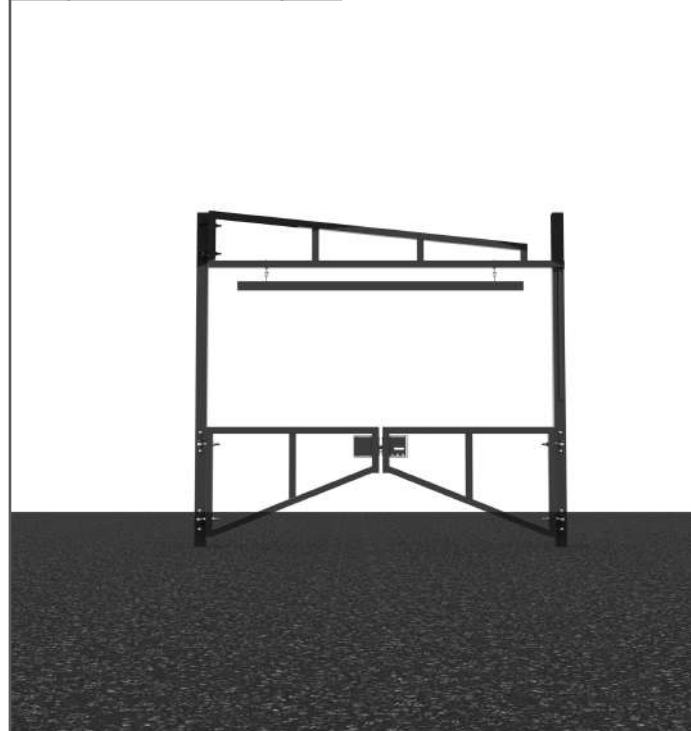
4b	Good Practice	✔
		



Notes:

All swing barrier kits will include the following catch post in corresponding colours to secure leaf in the open position:



1x SWI-CAT-0010 - CATCH KIT FOR HIGH LEVEL SWING ARM WITH NUDGE BAR ONLY

- For securing the upper swing barrier.

Illustration	Description	Product Code	Quantity
	2.2m HIGH SWING BARRIER DIG IN RECEIVER POST 100x100 BOX	SWI-REC-0010	1
	15MM PLASTIC RIBBED PLUG	UNI-SLIDE-5010	8
	100X100 BLACK RIBBED INSERTS	ACCS-RIB-0006	1

Car Park Swing Barrier

Built specifically for carpark security, this range of manual swing barriers offers standard 3m and 5m widths, alongside 4m and 6m wide versions equipped with telescopic arms to accommodate different site footprints. Every barrier is engineered for heavy-duty durability and features a locking bar used as a handle for effortless manual operation.





2.2M HIGH X 3.0M WIDE SWING BARRIER WITH HIGH LEVEL SWING ARM ONLY KIT

Size: (H) 2200mm x (W) 3000mm

A robust and dependable access control solution designed for securing driveways, small car parks, and private site entrances. This 3m wide kit provides a compact yet high-visibility deterrent, perfect for locations where space is at a premium but security is a priority.



Illustration	Description	Product Code	Quantity
	2.2m HIGH SWING BARRIER DIG IN HINGE POST 100x100 BOX	SWI-HIN-0010	1
	2.2m HIGH SWING BARRIER DIG IN RECEIVER POST 100x100 BOX	SWI-REC-0010	1
	0.5m HIGH X 3.0m WIDE HEIGHT BARRIER LEAF	SWI-LEAF-2100	1
	LOCK KIT FOR HEIGHT RESTRICTOR SWING BARRIER	SWI-LOCK-0010	1
	100X100 BLACK RIBBED INSERTS	ACCS-RIB-0006	2
	60X60 BLACK RIBBED INSERTS	ACCS-RIB-0003	2

	<p>ADJUSTABLE GATE EYE 150mm cw 20mm</p>	<p>ACCS-GEN-0001</p>	<p>2</p>
	<p>HEIGHT RESTRICTOR NUDGE BAR FIXINGS KIT</p>	<p>NUDG-KIT-0100</p>	<p>1</p>
	<p>NUDGE BAR 80x40mm x 2500mm WELDED LUGS</p>	<p>SWI-BAR-0350</p>	<p>1</p>
	<p>15MM PLASTIC RIBBED PLUG</p>	<p>UNI-SLIDE-5010</p>	<p>16</p>

2.2M HIGH X 4.0M WIDE EXTENDED SWING BARRIER WITH HIGH LEVEL SWING ARM ONLY KIT

Size: (H) 2200mm x (W) 4000mm

A robust and dependable access control solution designed for securing wider commercial driveways and medium-sized car parks. This 4m wide kit provides a high-visibility deterrent, making it the ideal choice for sites that require a broader clearance for utility vehicles while maintaining a compact footprint.

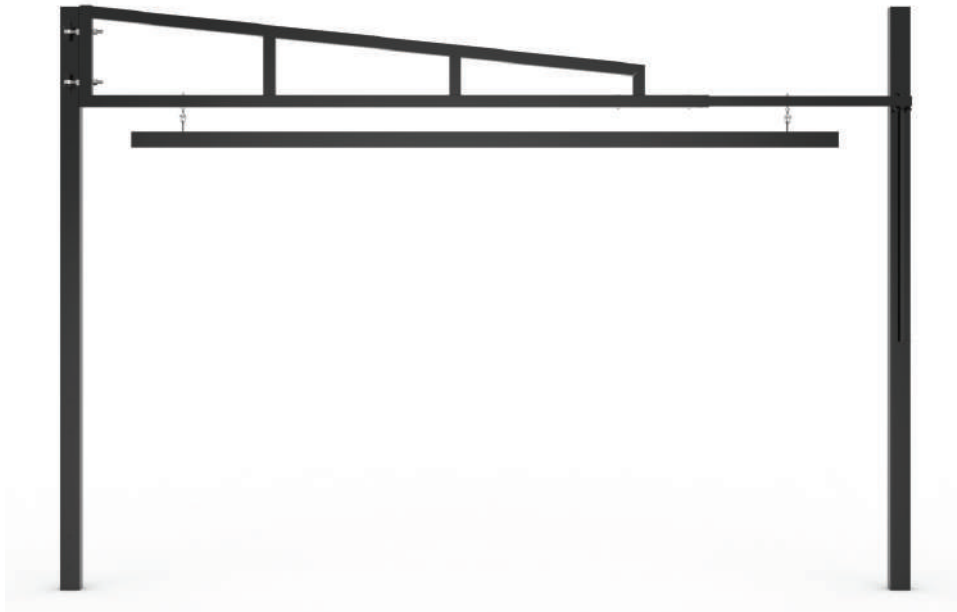









Illustration	Description	Product Code	Quantity
	2.2m HIGH SWING BARRIER DIG IN HINGE POST 100x100 BOX	SWI-HIN-0010	1
	2.2m HIGH SWING BARRIER DIG IN RECEIVER POST 100x100 BOX	SWI-REC-0010	1
	NUDGE BAR 80x40mm x 3500mm WELDED LUGS	SWI-BAR-0360	1
	0.5m HIGH X 3.0m WIDE HEIGHT BARRIER LEAF	SWI-LEAF-2100	1
	LOCK KIT FOR HEIGHT RESTRICTOR SWING BARRIER	SWI-LOCK-0010	1
	HEIGHT RESTRICTOR NUDGE BAR FIXINGS KIT	NUDG-KIT-0100	1
	STEEL HS 50x50x1.5mm x 1500 TELESCOPIC BEAM KIT	SWI-BAR-0400	1

	100X100 BLACK RIBBED INSERTS	ACCS-RIB-0006	2
	60X60 BLACK RIBBED INSERTS	ACCS-RIB-0003	1
	50X50 BLACK RIBBED INSERTS	ACCS-RIB-0010	1
	ADJUSTABLE GATE EYE 150mm cw 20mm	ACCS-GEN-0001	2
	15MM PLASTIC RIBBED PLUG	UNI-SLIDE-5010	16



2.2M HIGH X 5.0M WIDE SWING BARRIER WITH HIGH LEVEL SWING ARM ONLY KIT

Size: (H) 2200mm x (W) 5000mm

A robust and dependable access control solution designed for securing wider commercial driveways and medium-sized car parks. This 4m wide kit provides a high-visibility deterrent, making it the ideal choice for sites that require a broader clearance for utility vehicles while maintaining a compact footprint.



Illustration	Description	Product Code	Quantity
	2.2m HIGH SWING BARRIER DIG IN HINGE POST 100x100 BOX	SWI-HIN-0010	1
	2.2m HIGH SWING BARRIER DIG IN RECEIVER POST 100x100 BOX	SWI-REC-0010	1
	NUDGE BAR 80x40mm x 4500mm WELDED LUGS	SWI-BAR-0370	1
	0.5m HIGH X 5.0m WIDE HEIGHT BARRIER LEAF	SWI-LEAF-2110	1
	LOCK KIT FOR HEIGHT RESTRICTOR SWING BARRIER	SWI-LOCK-0010	1
	60X60 BLACK RIBBED INSERTS	ACCS-RIB-0003	2
	100X100 BLACK RIBBED INSERTS	ACCS-RIB-0006	2

	<p>ADJUSTABLE GATE EYE 150mm cw 20mm</p>	<p>ACCS-GEN-0001</p>	<p>2</p>
	<p>HEIGHT RESTRICTOR NUDGE BAR FIXINGS KIT</p>	<p>NUDG-KIT-0100</p>	<p>1</p>
	<p>15MM PLASTIC RIBBED PLUG</p>	<p>UNI-SLIDE-5010</p>	<p>16</p>

2.2M HIGH X 6.0M WIDE EXTENDED SWING BARRIER WITH HIGH LEVEL SWING ARM ONLY KIT

Size: (H) 2200mm x (W) 6000mm

A robust and dependable access control solution designed for securing wider commercial driveways and medium-sized car parks. This 4m wide kit provides a high-visibility deterrent, making it the ideal choice for sites that require a broader clearance for utility vehicles while maintaining a compact footprint.

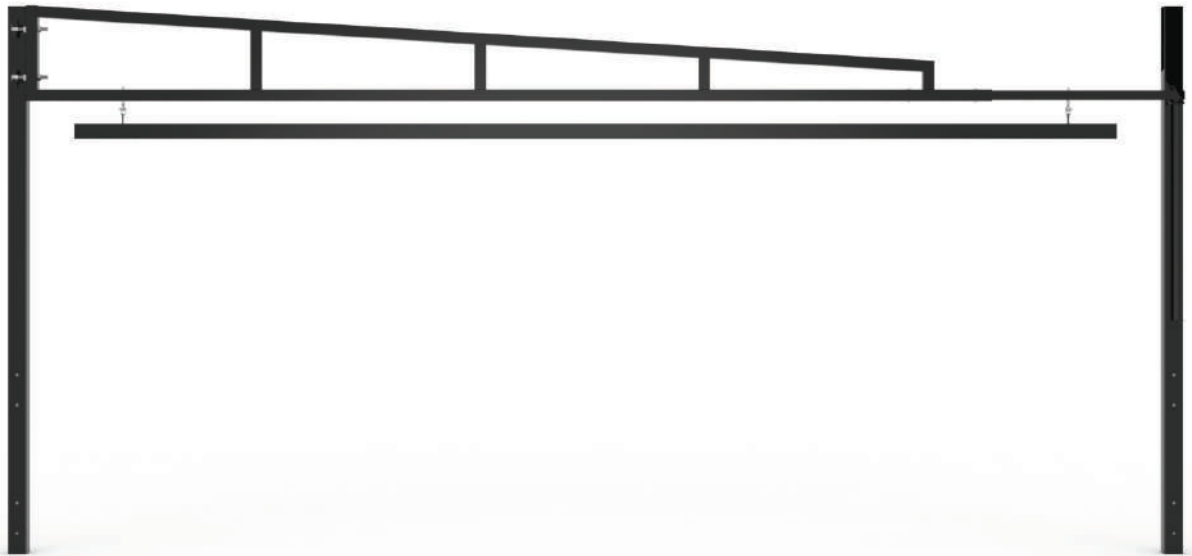











Illustration	Description	Product Code	Quantity
	2.2m HIGH SWING BARRIER DIG IN HINGE POST 100x100 BOX	SWI-HIN-0010	1
	2.2m HIGH SWING BARRIER DIG IN RECEIVER POST 100x100 BOX	SWI-REC-0010	1
	NUDGE BAR 80x40mm x 5500mm WELDED LUGS	SWI-BAR-0380	1
	0.5m HIGH X 5.0m WIDE HEIGHT BARRIER LEAF	SWI-LEAF-2110	1
	LOCK KIT FOR HEIGHT RESTRICTOR SWING BARRIER	SWI-LOCK-0010	1
	HEIGHT RESTRICTOR NUDGE BAR FIXINGS KIT	NUDG-KIT-0100	1
	STEEL HS 50x50x1.5mm x 1500 TELESCOPIC BEAM KIT	SWI-BAR-0400	1

	100X100 BLACK RIBBED INSERTS	ACCS-RIB-0006	2
	60X60 BLACK RIBBED INSERTS	ACCS-RIB-0003	1
	50X50 BLACK RIBBED INSERTS	ACCS-RIB-0010	1
	ADJUSTABLE GATE EYE 150mm cw 20mm	ACCS-GEN-0001	2
	15MM PLASTIC RIBBED PLUG	UNI-SLIDE-5010	16

The Car Park Swing Barrier Range

The Car Park Swing Barrier range is designed to provide high-level vehicle access control for private car parks, public car parks, and community areas. This versatile range combines a robust physical gate with an integrated height restrictor to manage both the size and flow of traffic effectively.

Whether you need a compact 3m span or a wide 6m entrance, each kit is engineered for safety, longevity, and professional presentation.

Key Features

- **Standardised Ultra-Robust Support:** To ensure maximum structural integrity across the entire range, every kit - from 3m to 6m - features heavy-duty 100mm x 100mm steel support posts.
- **Industrial-Grade Construction:** Built from high-tensile square hollow section (SHS) steel, engineered to withstand the rigors of high-traffic environments like schools, industrial estates, and retail parks.
- **Enhanced Safety:** Designed for use with optional secondary catch posts, allowing the leaves to be safely locked in the open position to prevent accidental swinging or unauthorized closure.

Weather-Proof Finishes:

Galvanized Protection: All components are hot-dip galvanized as standard for long-term rust prevention.

Optional Powder Coating: Available in our standard RAL colours for a professional, durable finish that matches your site's aesthetic.

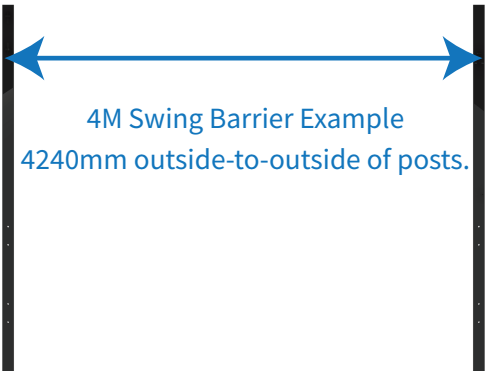
1	Measure and mark the exact post positions on the ground. For this style, you must achieve the correct corresponding measurement outside-to-outside post width to ensure the gate and hinges fit correctly.
	
	

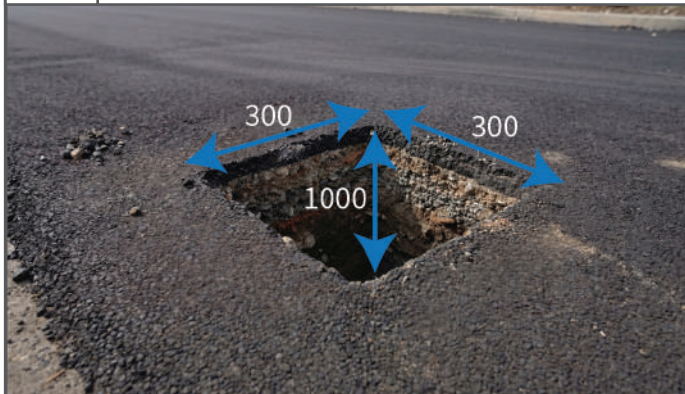
2	Dig two holes for your gate posts. According to the technical drawing, the foundation depth must be 1000mm to properly secure the 3900mm total length posts.
	
	

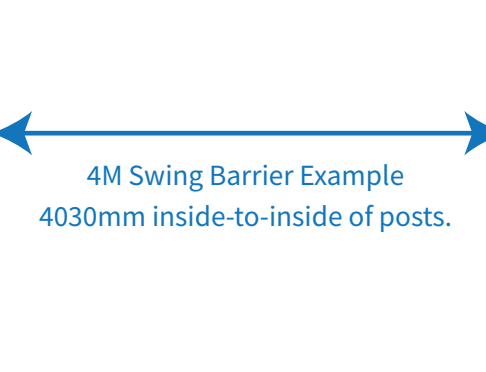
3	Place the 100x100mm hinge and catch posts into their respective holes. Ensure both posts are perfectly vertical (plumb) and aligned with each other.
	
	

4	Secure the posts using concrete or post mix. Double-check that both posts remain perfectly plumb and aligned before the concrete fully cures.
	
	

5	Move on to the upper swing barrier leaf. Carefully lift into position and secure with eye bolts and nuts. Take care when lifting at height.
	
 2+ PEOPLE REQUIRED	

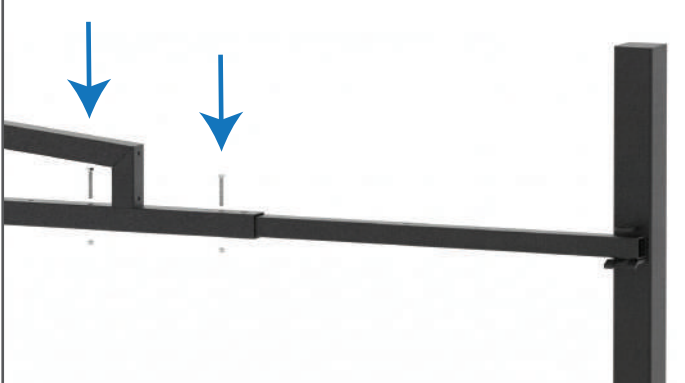
6	If using a 4M or 6M Kit, now is the time to install the telescopic bar to achieve full length. Secure with provided nuts and bolts. Do not attach ribbed inserts till after step 10.
	
	



Note: Ensure all M12 snap-off security nuts on the back of the bolt on hook kit assemblies are fully tightened and sheared off to prevent tampering!

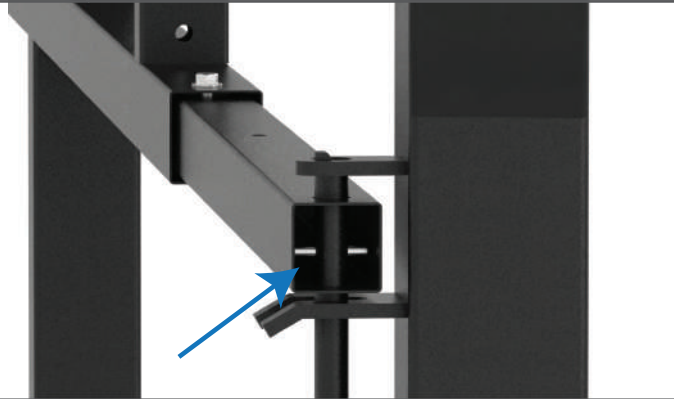

7	Ensure the swing barrier moves freely, and aligns with the catch post. Attach the swing barrier locking kit as shown below. Attach bolt pin from locking kit to stop bar from sliding out.
	
	

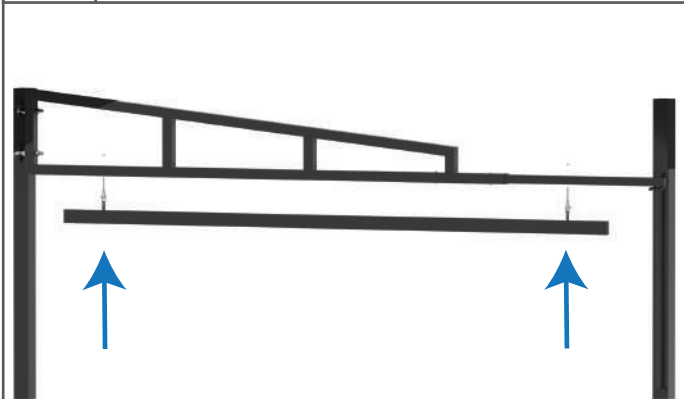
8	Attach the nudge bar using the provided fixing kit. Adjust fixings until nudge bar sits level. Attach all ribbed inserts.
	
	

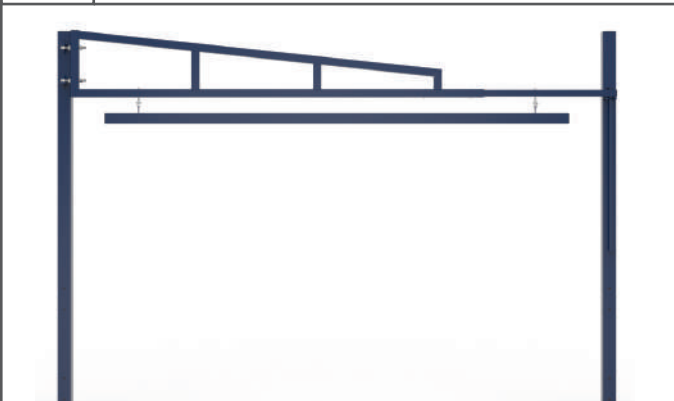
9	Ensure all leaves move freely across full opening arc. Tighten all security nuts and make sure they are sheared off to prevent tampering.
	
	

10	Mark out placement for the upper swing barrier catch post. It should be the same distance as the other receive post.
	
	

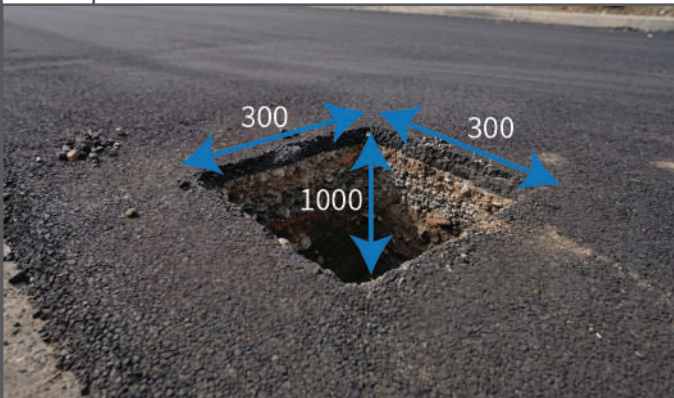
11	Dig out the marked hole for your upper swing barrier catch posts. This catch posts should sit 1000mm into the ground.
	
	

12	Secure the post using concrete or post mix. Double-check that post remain perfectly plumb and aligned before the concrete fully cures.
	
	



Note: Ensure all M12 snap-off security nuts on the back of the bolt on hook kit assemblies are fully tightened and sheared off to prevent tampering!



3.0 Installation Sign-Off Checklist

Action	Description	Consequence	Pass or Fail?	Remedial Action	Initial	Date
Ground Clearance Check	Ensure a strict 50mm ground clearance is maintained beneath the gate leaves across its entire opening arc.	Non-compliant gaps increase the risk of grounding. If this is not correct, the gates may fail to open and close properly.		Re-level the ground across the gate's opening arc to achieve a uniform 50mm clearance.		
Manual Operation & Locking Check	Test the barrier to ensure it swings smoothly on its hinges without excessive force. Verify that sliders, padlocks, and catch posts align perfectly in both the open and closed positions.	A stiff barrier poses a manual handling risk. Failure to lock whilst closed compromises car park / site security.		Adjust leaf alignment to ensure locking mechanisms engage smoothly without needing to be forced.		
Hardware & Security Checks	Inspect eye bolts, padlock shrouds, and drop bolts. Firmly push the main hinge post and catch posts to check for any wobble, movement, or degradation in the concrete foundations at ground level.	Ground subsidence or failing concrete can cause the barrier to lean, sag, drag on the ground, or eventually fail entirely. Loose hinges compromise security and operation.		If posts move, the concrete foundation has failed and must be broken out and re-poured. Replace damaged components. Ensure any exposed security nuts are sheared off to prevent tampering.		
Site Clean Up & Snagging	Conduct a final walk-through. Ensure all construction debris, leftover concrete, packaging, and tools are thoroughly removed from the car park and surrounding walkways.	Leftover debris presents puncture risks for vehicle tires and trip hazards for pedestrians. Overlooked defects lead to a substandard finish.		Sweep the area thoroughly, remove all waste, touch up any paint chips on the barrier, document any snags, and resolve them before final handover.		

Sign Off Declaration:

I hereby confirm that this product has been assembled and installed in accordance with the above requirements and any remedial works have been carried out before the final sign off:

Site Supervisor

Sign Off Date

Relationship to the Client

Signature



Note: This is an advisory best practice installation checklist to ensure your PlaySecure® hydraulic gates remain operational, effective, and safe.



4.0 Maintenance Schedule

Check Area	Result	Action
Ensure all steel components are periodically cleaned of bird matter, debris and dirt	This will minimise the harbouring of corrosive matter, which could affect paint and galvanising long term	Pressure wash gently to ensure clear of debris
Ensure gates maintain a strict 50mm ground clearance across the entire opening arc	Non-compliant gaps increase the risk of grounding. If this is not correct, the gates may fail to open and close properly.	Adjust leafs to restore the 50mm clearance or re-level the ground beneath the gate's swing path.
Ensure minimal wobble in the main pivot and catch posts to verify concrete foundation integrity. Check that locking mechanisms are secure.	Wobble indicates failing concrete foundations, which causes misalignment and sagging. Stiff or insecure locking mechanisms make the barrier hard to secure and vulnerable to tampering.	If posts move, the concrete foundation has failed and must be broken out and re-poured.

Take the hassle out of your maintenance schedule

First Fence Limited offers an annual inspection programme for your Swing Barrier System.

Contact our team today to include this quote onto your sales order.

highsecuritymaintenance@firstfence.co.uk

Operational Notes

1.0 These swing barriers and posts are designed specifically for secure vehicle access control in car parks. Additional loads such as people climbing/sitting on the barrier arm, attaching heavy equipment, or mounting oversized signage may cause deformation or damage to the hinge system and foundations.

2.0 All moving components must be inspected regularly for wear, damage, or misalignment. Replace or repair components as necessary to maintain safe, smooth manual operation and prevent manual handling strain.

3.0 The barriers should always be securely padlocked when in the fully closed position to the main catch post. This ensures secure access control and prevents the barrier arm from swinging freely into the path of moving vehicles or pedestrians.

4.0 All fixings should be tightly secured and free from excessively sharp or protruding edges to prevent minor injuries or clothing snags for the personnel operating the barrier and pedestrians walking nearby.

