

DO NOT SCALE DRAWING

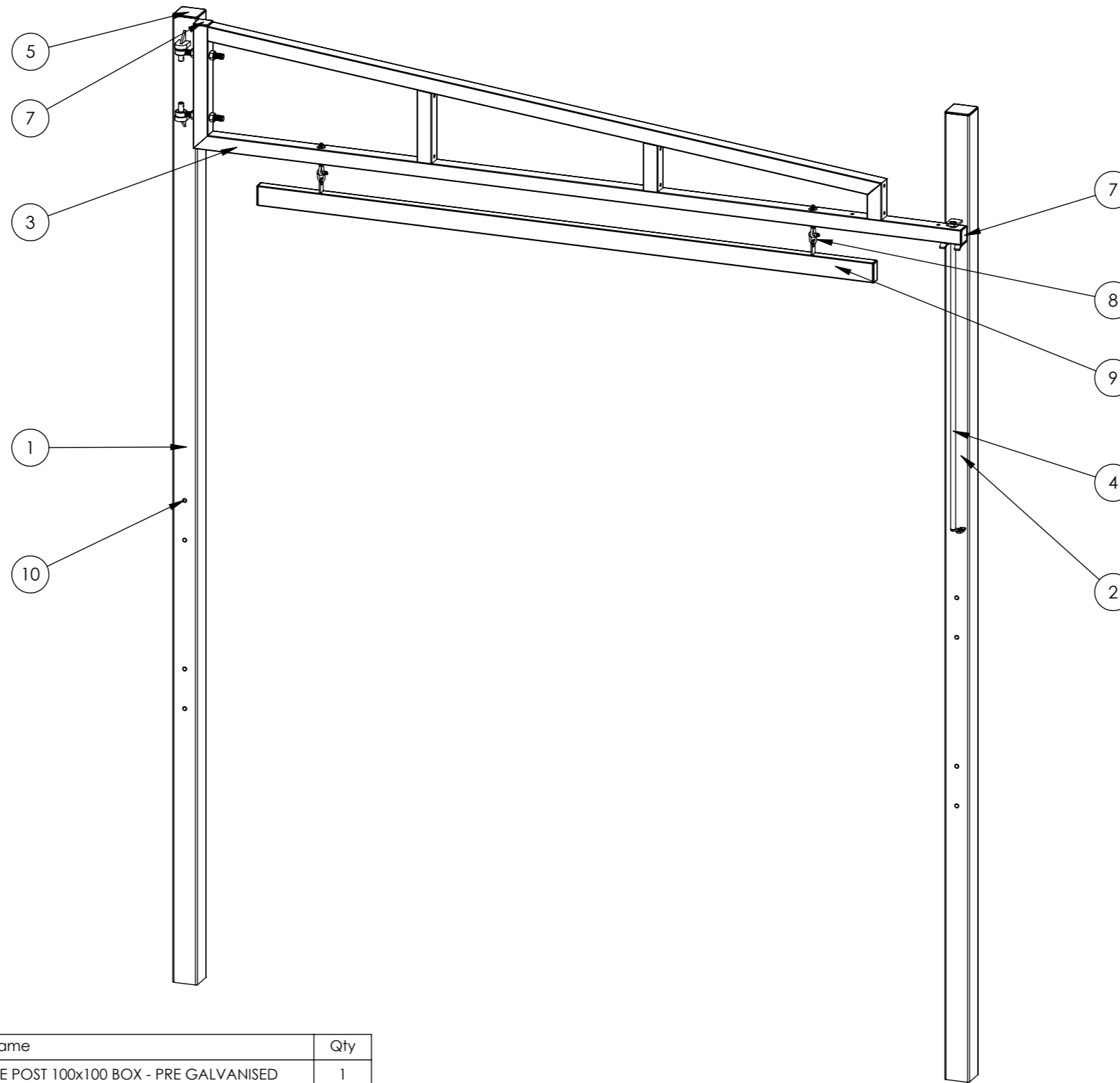

Notes:

1. All materials to be mild steel and conform to relevant British standards.
2. All items to be pre-galvanised to BS EN 10346 or hot dip galvanised to ISO 1461.
3. Items can be powder coated on request, to custom colours to : BS EN 13438.

Item	Component Name	Qty
1	SWI-HIN-0010 - 2.2m HIGH SWING BARRIER DIG IN HINGE POST 100x100 BOX - PRE GALVANISED	1
2	SWI-REC-0010 - 2.2m HIGH SWING BARRIER DIG IN RECEIVER POST 100x100 BOX - PRE GALVANISED	1
3	SWI-LEAF-2100 - 0.5m HIGH X 3.0m WIDE HEIGHT BARRIER LEAF - PRE GALVANISED	1
4	SWI-LOCK-0010 - LOCK KIT FOR HEIGHT RESTRICTOR SWING BARRIER	1
5	ACCS-RIB-0006 - 100X100 BLACK RIBBED INSERTS	2
6	ACCS-GEN-0001 - ADJUSTABLE GATE EYE 150mm cw 20mm	2
7	ACCS-RIB-0003 - 60x60 BLACK RIBBED INSERTS	2
8	NUDG-KIT-0100 - HEIGHT RESTRICTOR NUDGE BAR FIXINGS KIT	1
9	SWI-BAR-0350 - NUDGE BAR 80x40mm x 2500mm WELDED LUGS	1
10	UNI-SLIDE-5010 - 15MM PLASTIC RIBBED PLUG	16
11	SWI-CAT-0010 - CATCH KIT FOR HIGH LEVEL SWING ARM WITH NUDGE BAR ONLY	1

REV	DESCRIPTION	DATE

NAME	DATE	
DRAWN	A.T 08/06/2026	
APVD		
Tolerance	0 - 50mm ± 0.2mm	SKU: SWI-KIT-3050
	> 50 - 500mm ± 1mm	
	> 1000mm ± 3mm	
Third Angle Projection		TITLE:
Material: STEEL		2.2M HIGH X 3.0M WIDE SWING BARRIER WITH HIGH LEVEL SWING ARM ONLY KIT
WEIGHT: 100.2 KILOGRAMS ± 5%	SCALE: 1:20	REV A A3
SHEET 1 OF 3		



DO NOT SCALE DRAWING

Notes:

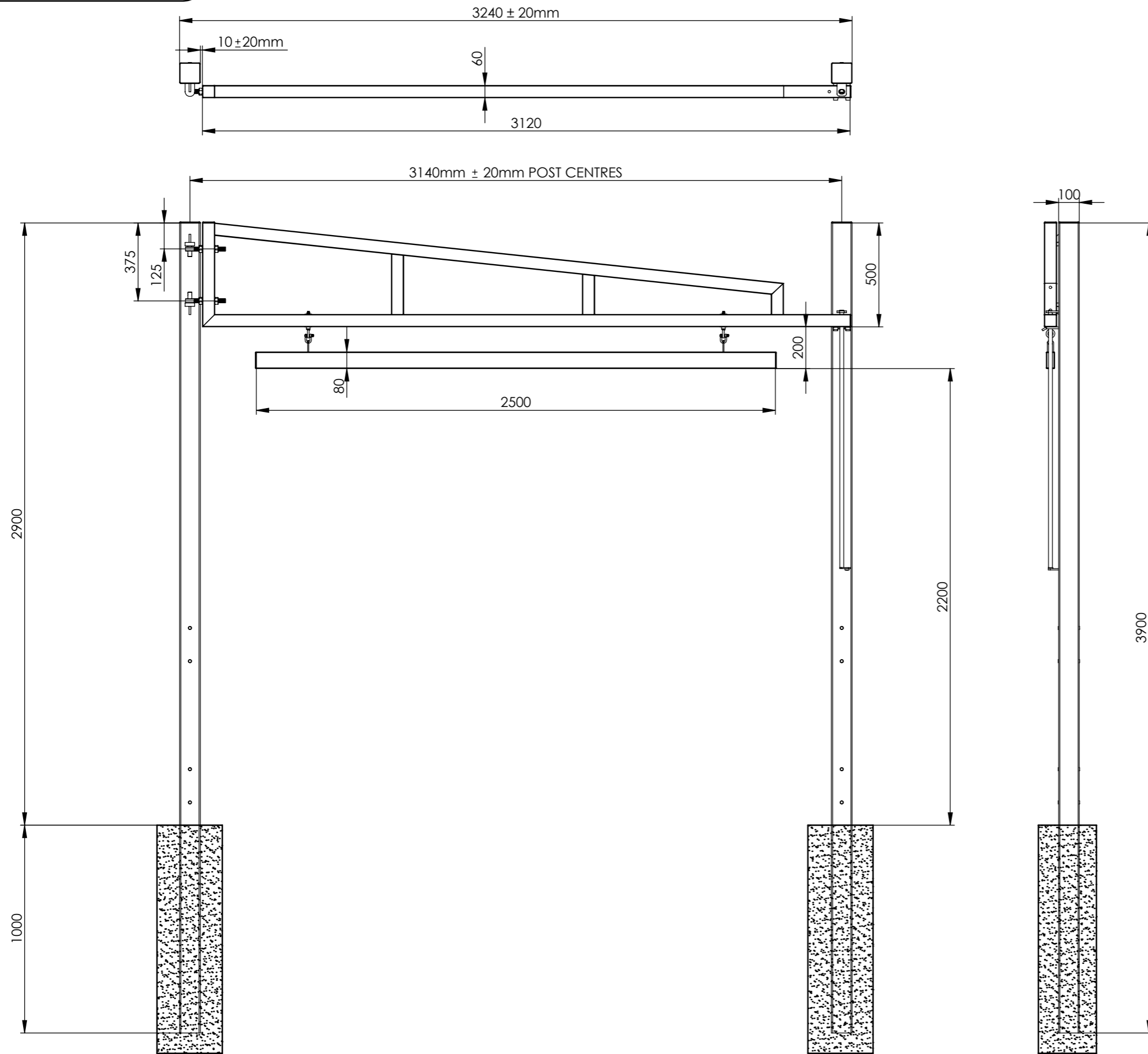
1. All materials to be mild steel and conform to relevant British standards.
2. All items to be pre-galvanised to BS EN 10346 or hot dip galvanised to ISO 1461.
3. Items can be powder coated on request, to custom colours to : BS EN 13438.



REV	DESCRIPTION	DATE

DRAWN	NAME	DATE	 SWI-KIT-3050
APVD	A.T	08/06/2026	
Tolerance	0 - 50mm	$\pm 0.2\text{mm}$	
	> 50 - 500mm	$\pm 1\text{mm}$	SKU:
	>1000mm	$\pm 3\text{mm}$	
 Third Angle Projection			TITLE:
Material: STEEL			2.2M HIGH X 3.0M WIDE SWING BARRIER WITH HIGH LEVEL SWING ARM ONLY KIT
WEIGHT: 100.2 KILOGRAMS $\pm 5\%$			REV A A3
SCALE: 1:20		SHEET 2 OF 3	

DO NOT SCALE DRAWING

Notes:

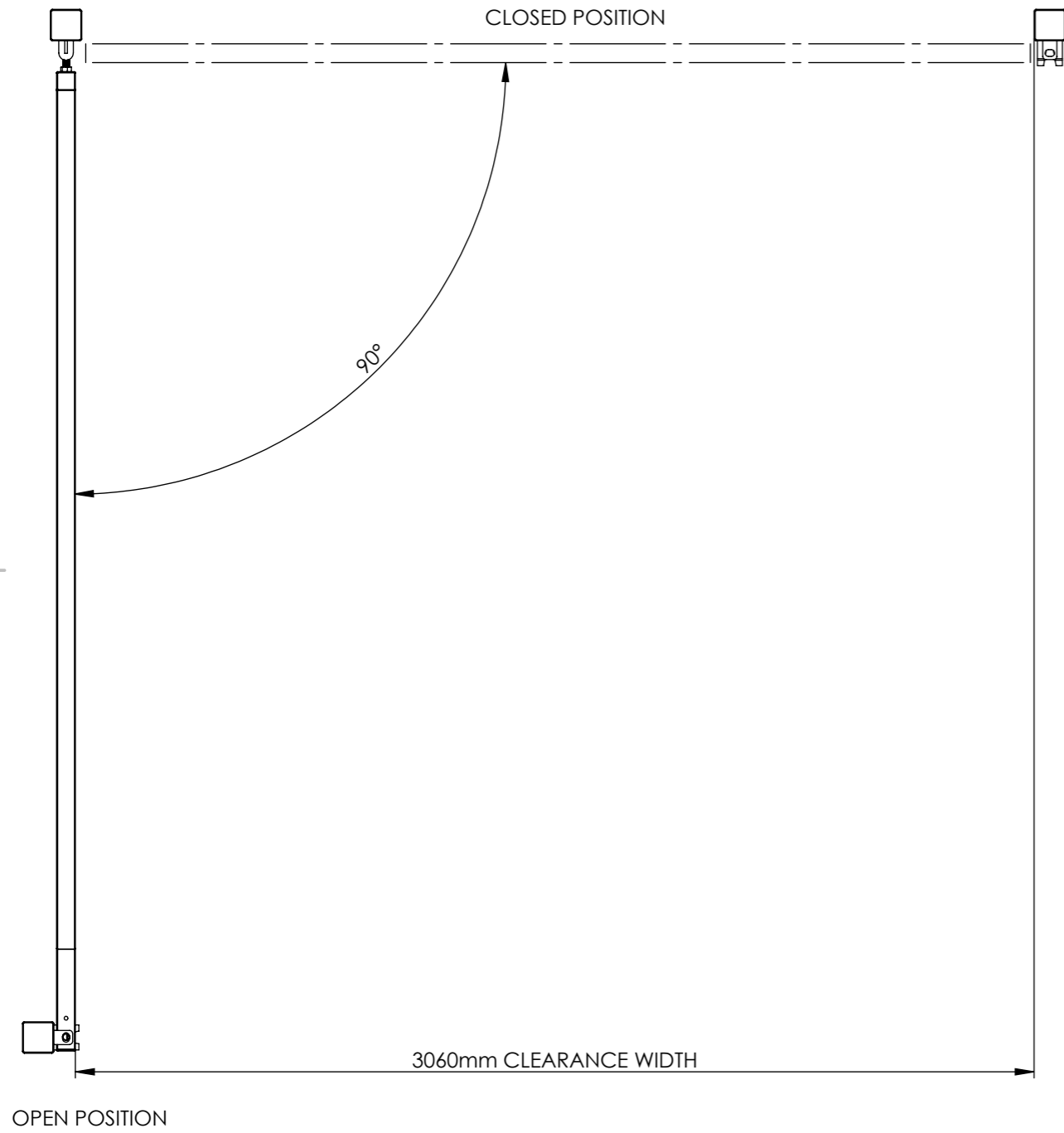

SWI-CAT-0010 - CATCH KIT FOR HIGH LEVEL SWING ARM WITH NUDGE BAR ONLY

ALL HIGH LEVER SWING BARRIER ONLY KITS COME WITH CATCH KIT FOR SECURING BARRIER IN OPEN POSITION

REV		DESCRIPTION	DATE
DRAWN		A.T	08/06/2026
APVD			
Tolerance	0 - 50mm	± 0.2mm	SKU:
	> 50 - 500mm	± 1mm	
	>1000mm	± 3mm	
Third Angle Projection		SWI-KIT-3050	
Material: STEEL		TITLE: 2.2M HIGH X 3.0M WIDE SWING BARRIER WITH HIGH LEVEL SWING ARM ONLY KIT	
WEIGHT: 100.2 KILOGRAMS ± 5%		SCALE: 1:20	SHEET 3 OF 3

REV
A
A3