

For insert locks

SFKM



<https://www.locinox.com/en-gb/gate-hardware/keeps/for-insert-locks/d0000057>

Aesthetical surface mounted keep for small metal, aluminium and PVC gates. Specially designed for Fortylock, Fiftylock and Sixtylock insert locks. The limited 8 mm depth ensures a discreet look. A highly efficient assembly with minimal gate preparations is guaranteed, while the unique Quick-Fix ensures a fast and strong fixation on the gate. This unique keep in combination with the insert lock ensures a strong gate anchoring.

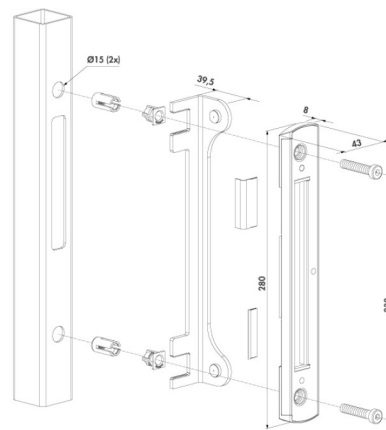

TECHNICAL SPECIFICATIONS

Left-Right Adjustability	Yes
Installation Method	Hexagon Screws (HEX 5) Quick-Fix
Profile Type	Square
Gate Profile	$40 \leq x \leq 60$ mm
Minimal Distance Gate - Post	15 mm
Materials Main Part(s)	Polypropylene Powder Coated Aluminium Stainless Steel
Hours of Salt Spray Testing	500
Test Frequency	500000
Years of Warranty	3