

For insert locks

SFKB



<https://www.locinox.com/en-gb/gate-hardware/keeps/for-insert-locks/d00000055>

Stainless steel keep with polyamide finishing for all your metal, aluminium and PVC gates. The patented stainless steel anchoring system prevents pulling the gates out of the keep. The unique Quick-Fix ensures a fast and strong mounting.

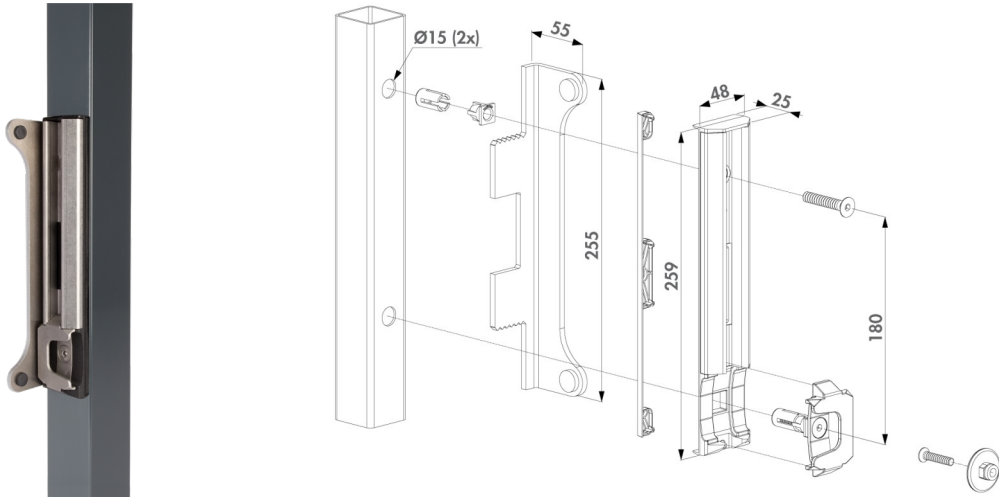

TECHNICAL SPECIFICATIONS

Left-Right Adjustability	Yes
Installation Method	Hexagon Screws (HEX 5) Quick-Fix
Profile Type	Square
Gate Profile	$40 \leq x \leq 60$ mm
Minimal Distance Gate - Post	30 mm
Materials Main Part(s)	Powder Coated Aluminium Stainless Steel
Hours of Salt Spray Testing	500
Test Frequency	500000
Years of Warranty	3