

# LOKQY2

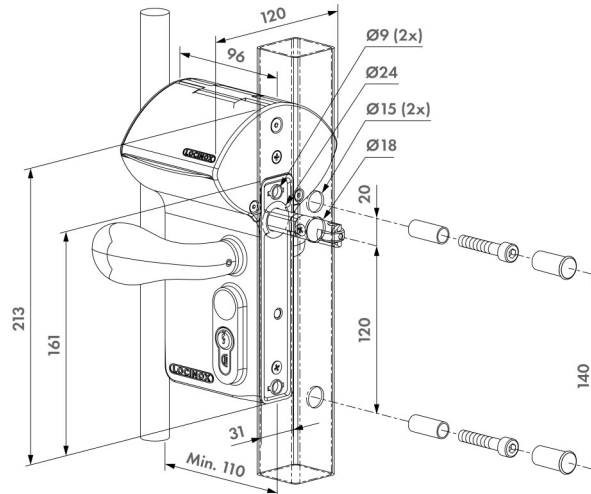

<https://www.locinox.com/en-gb/gate-hardware/locks/standard-code-locks/d00000036>

High quality battery powered electronic code lock with aluminium housing. Valentino's energy efficient design makes it very easy to equip any gate with access control, with a minimal need for maintenance. Pincodes can be easily added, modified or removed. The 20 mm continuous adjustability of the bolts allows a perfect latching / locking of the mechanism.



## TECHNICAL SPECIFICATIONS

<b>Left-Right Adjustability</b>	Yes
<b>Installation Method</b>	Hexagon Nuts (HEX 5) + Spacers
<b>Daybolt Adjustability</b>	20 mm
<b>Follower Size</b>	Square 8 mm
<b>Profile Type</b>	Flat Round Square
<b>Cylinder Length</b>	46 mm
<b>Power</b>	Operates on batteries, battery pack included
<b>Materials Main Part(s)</b>	KTL And Spray Coated Aluminium Housing Polyacetal Polyethylene Cover Stainless Steel Mechanism
<b>Hours of Salt Spray Testing</b>	1000
<b>Test Frequency</b>	500000
<b>Years of Warranty</b>	3