

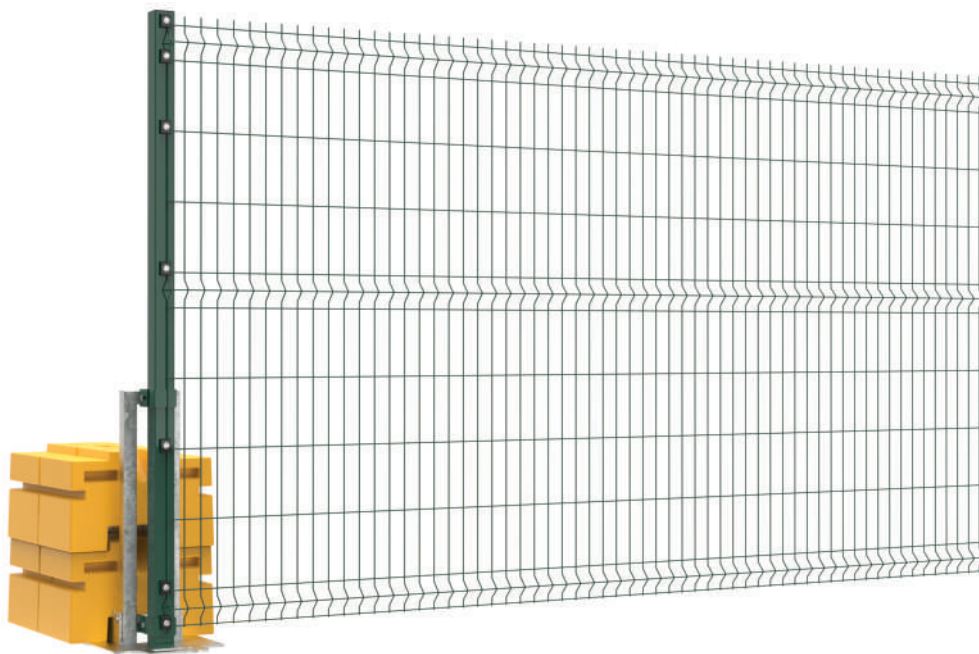

# RapidShield®



## Operations, Maintenance & Installation Manual

Proudly Compliant with:



Proud to work with our partners



This manual provides a comprehensive overview of the installation, operation, inspection, and maintenance requirements for the First Fence RapidShield® product range.

RapidShield® is a modular rapid deployment fencing system designed to provide a secure perimeter solution for temporary and semi-permanent applications. The system combines the strength and security of rigid mesh fencing with the flexibility and speed of installation typically associated with temporary fencing systems, making it suitable for construction sites, infrastructure projects, utilities, events, and other security-sensitive locations.

The RapidShield® range has been engineered to facilitate quick installation and removal without the need for excavation or concrete foundations. Utilising the RapidShield® UniFoot ballast system, the fence can be deployed efficiently while maintaining stability and security in accordance with site-specific requirements.

Designed for repeated use, the system consists of modular fencing panels, posts, ballast units, and security fixings that can be assembled, dismantled, and redeployed as project requirements change. To ensure continued performance and safety, all components should be installed, inspected, and maintained in accordance with the guidance provided within this manual.

**Disclaimer:** This guide is for informational purposes only. The installer is responsible for ensuring the installation complies with all relevant British Standards, local building regulations, codes of practice, and site-specific risk assessments. While every attempt has been made to verify the accuracy of the content in this guide upon its release, we cannot accept liability for any losses or damages resulting from inaccuracies. All tasks outlined must be carried out by certified professionals. Any deviation from these instructions nullifies any guaranteed entitlement or liability from the manufacturer.

**Copyright:** The copyright of this guide is owned by First Fence Ltd and is protected at all times. Reproduction of this guide by any means is strictly prohibited without prior written consent from First Fence Ltd.

**Contact:** For enquiries regarding the installation, operation or contents of the guide in relation to this product please direct your questions to : The Product and Drawing Office Manager, First Fence Ltd, Off Kiln Way, Swadlincote, South Derbyshire DE11 8EA. Or The Product and Drawing Office Manager sales@firstfence.co.uk +44 1283 380054.

**Manufacturer and/or Reseller:** First Fence Ltd, Off Kiln Way, Swadlincote, South Derbyshire DE11 8EA. www.firstfence.co.uk +44 1283 380054.

**Competence:** This product must be installed by a person of competence, defined as an individual who possesses the necessary knowledge, skill and experience in the installation of fences and gates.

**Liability:** This installation guide should be understood and followed before any installation activities commence. If any area of the installation is unclear, the installer must contact the manufacturer, outlined in 'Contact.' First Fence Ltd takes no responsibility for incorrectly installed systems, product, material or components.

Please see the suitability table below to determine whether RapidShield® is appropriate for the intended site, application, and security requirement.

Application	Construction Sites	Infrastructure Projects	Utilities	Events & Crowd Management	Temporary Security	Semi-Permanent Security
RapidShield V-Mesh	3	3	2	1	1	1
RapidShield 868 Mesh	2	3	2	1	1	1
RapidShield 358 Mesh	2	2	2	1	1	1

#### Legend

1 = Preferred	2 = Suitable	3 = Unsuitable
---------------	--------------	----------------

## Design Specification

Key design criteria met (full list can be obtained on request):

Design Criteria	Specific Design Specification	RapidShield® Criteria
Rapid Deployment	System should allow quick installation and removal with minimal ground preparation.	Modular design enables efficient installation and dismantling without excavation or concrete foundations.
Stability & Ballast Performance	System must remain stable when installed in accordance with the specified ballast requirements.	Utilises the RapidShield® UniFoot ballast system to provide a secure and stable perimeter solution.
Security Fixings	Components should be secured using tamper-resistant fixings to deter unauthorised removal.	Security fixings are supplied as standard and require a specialist installation tool.
Modular Configuration	System should allow flexible layouts to suit varying site requirements.	Compatible components allow straight runs, corners, gates, and bespoke perimeter arrangements.
Durability	Components should withstand repeated installation, removal, transportation, and storage.	Manufactured from galvanised steel components designed for multiple deployment cycles.
Inspection & Maintenance	System should be routinely inspected to ensure continued performance and safety.	Visual inspections should be carried out regularly to verify the condition of panels, posts, fixings, and ballast units.

Note: RapidShield® is designed as a temporary or semi-permanent perimeter security system. The stability and performance of the installation are dependent upon correct assembly, ballast configuration, ground conditions, and compliance with the installation instructions provided within this manual.

# 1.0 Safety & Tools

---

## Personal Protective Equipment (PPE)

The following minimum PPE is required for installation:

**Hard Hat**  
Must be worn



**Eye Protection**  
Must be worn



**Safety Gloves**  
For all material handling



**Foot Protection**  
Must be worn



## Risk Assessment

Installers are responsible for completing a site-specific risk assessment and complying with all local risk assessments before starting work. This responsibility includes, but isn't limited to, the following:

Activity	Risk Assessment Requirements and Not Limited to
Positioning and Levelling UniFoots	Noise Vibration Manual Handling
Post Installation	Manual Handling
Installation of Fixings	Noise Vibration Working at Height

## Tools & Equipment

### Safety Gloves

Required for all material handling, any COSHH tasks including Post Mix, and any installation tasks.



### Drill/Buzz Gun

For fixings installation



### Shovel/Excavation

Required for excavation of holes to suit post foundations



### Spirit Level

For plumb (vertical) and level installation



### Time

Required for Post Mix curing or patched fixing curing

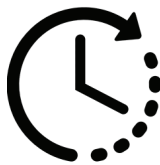

### Cable Avoidance Tool

To identify hidden services embedded in the wall



## 2.0 Pre-Installation

---

### Clearing Site

Prior to installation, ensure the proposed fence line is free from obstructions and provides sufficient space for the installation of panels, posts, ballast units, and any associated gates. Ground conditions should be assessed to ensure the surface is capable of supporting the RapidShield® system and ballast arrangement.



### Materials Check

Unpack the kit and verify all components are present and undamaged, checking against the Bill of Materials (Section 4.0). Ensure all panels, posts, ballast units, brackets, and fixings are free from excessive corrosion, deformation, or transit damage before installation.



# Site Preparation For RapidShield®

here must be sufficient clear space maintained around the installation area to allow for the safe assembly and positioning of all RapidShield® components. The proposed fence line should be free from obstructions, and adequate access should be available for the movement and placement of panels, posts, ballast units, and associated equipment.

## Note: Gate Installation Clearing

<b>1</b>	Before beginning installation, coordinate with a site manager if needed. Ensure the ground is cleared and prepared for installation.
	
	

## Note: Clearance Gap

<b>2</b>	Ground clearance requirements vary between fencing and gate kits. A 50mm clearance is typical for most installations; however, the required clearance may differ depending on the system.
	Always refer to the technical drawings to confirm the correct clearance before installation.
	



**Note: Failure to install the RapidShield® system on suitably level ground may result in poor system performance, component misalignment, and difficulties during assembly and operation.**



## Note: Ground Level

The RapidShield® system is designed to be installed on suitably level and stable ground to ensure correct alignment and performance. Installation on uneven or sloping surfaces may result in component misalignment, reduced system stability, difficulties during assembly, and may prevent the system from performing as intended.

<b>4a</b>	Bad Practice	<b>✘</b>
		

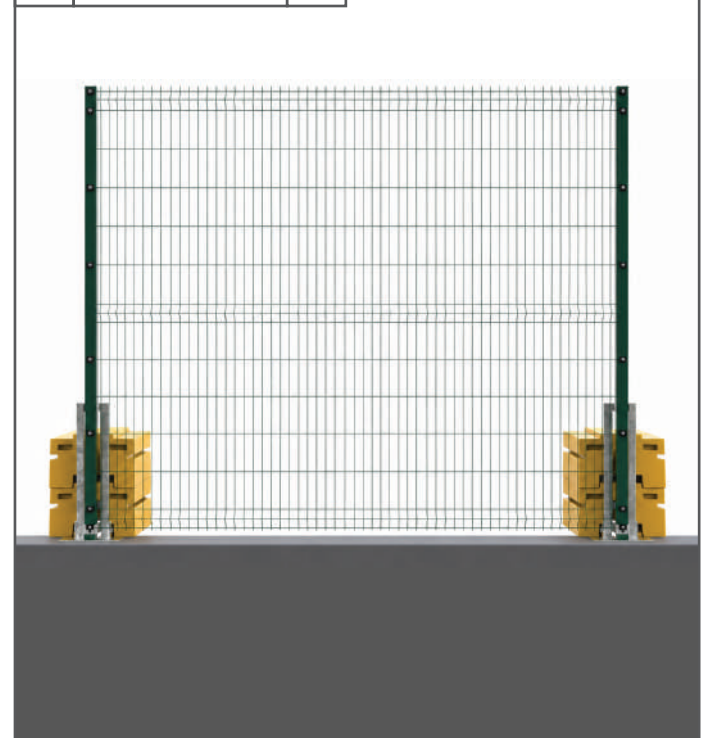
<b>4b</b>	Good Practice	<b>✔</b>
		

## RapidShield® Fencing System

The RapidShield® fencing system offers a range of configurations to suit different site requirements. All systems are engineered for durability, stability, and rapid deployment. Designed for temporary and semi-permanent perimeter security applications.

### RapidShield® 1.8M - 3.0M High V Mesh Fencing System

A versatile rapid deployment fencing solution suitable for construction sites, events, and temporary perimeter security applications. The RapidShield® V Mesh system provides a secure and stable perimeter using rigid V Mesh panels, steel posts, ballast units, and security fixings.

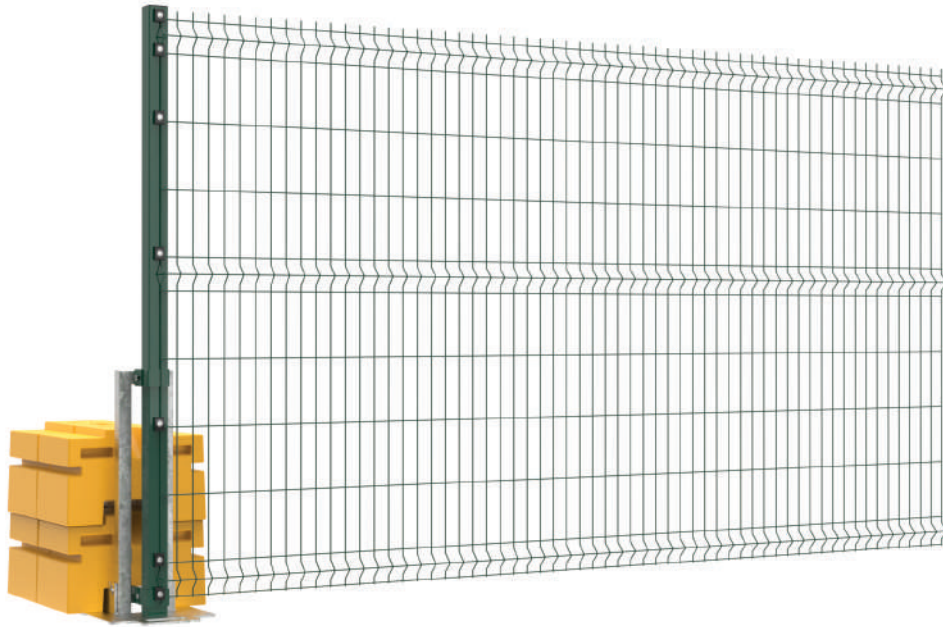







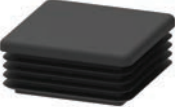

Illustration	Description	Product Code	Quantity
	RAPIDSHIELD 1.8m - 3.0M HIGH INTERMEDIATE POST 60x60mm BOX WITH ELLIPSE HOLE	N/A	1
	RAPIDSHIELD® - UNIFOOT FULL ASSEMBLY	RAPID-UNIFOOT-1000	1
	1.8M - 3.0M HIGH X 2.5M - 3.0M WIDE V MESH FENCE PANEL ONLY - 4MM	N/A	1
	Durablock Pre-Filled Ballast Block - 50kg	TEMP-BAL-0003	4
	M8 x 35MM STAR PROFILE SECURITY SCREW - STAINLESS STEEL	RAPI-SHIELD-0005	8 - 10
	UNIVERSAL MESH FENCING BLACK FIXING CLIPS	ACCS-MSH-0001	7 - 9

	HEX HEAD BOLT M8 X 90mm	ACCS-GEN-0090	1
	M8 HEX NUT	API-SHIELD-0065	1
	60x60 BLACK RIBBED INSERTS	ACCS-RIB-0003	1

RapidShield® 1.8M - 3.0M High 358 Mesh Fencing System

A high-security rapid deployment fencing solution designed for sites requiring enhanced protection against intrusion. The RapidShield® 358 Mesh system combines anti-climb mesh panels, steel posts, ballast units, and security fixings to provide a robust temporary perimeter.

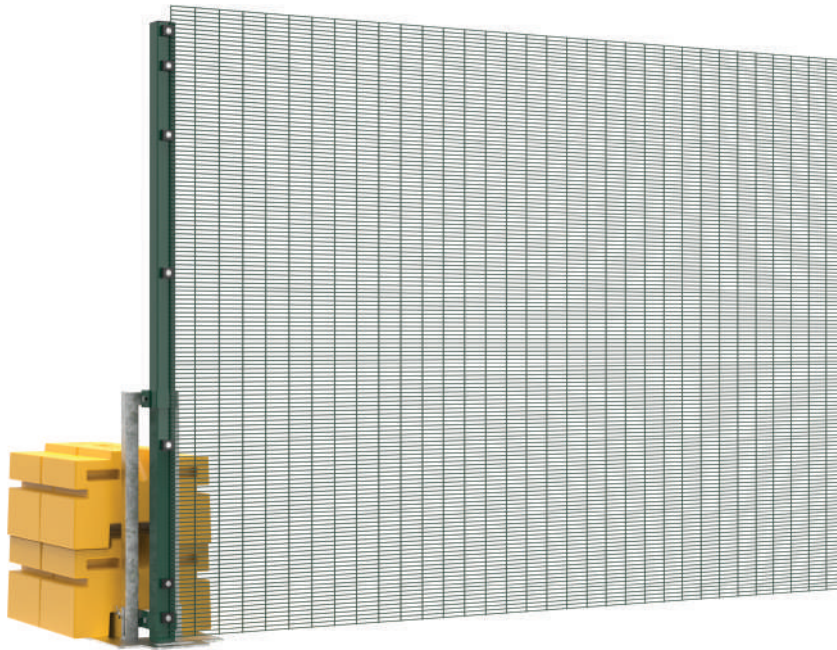

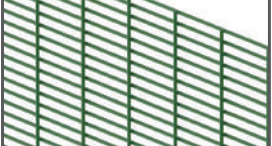





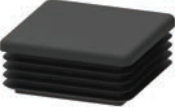







Illustration	Description	Product Code	Quantity
	RAPIDSHIELD 1.8m - 3.0M HIGH INTERMEDIATE POST 60x60mm BOX WITH ELLIPSE HOLE	N/A	1
	RAPIDSHIELD® - UNIFOOT FULL ASSEMBLY	RAPID-UNIFOOT-1000	1
	1.8M - 3.0M HIGH X 2.5M WIDE 358 MESH FENCE PANEL ONLY	N/A	1
	Durablock Pre-Filled Ballast Block - 50kg	TEMP-BAL-0003	4
	M8 x 35MM STAR PROFILE SECURITY SCREW - STAINLESS STEEL	RAPI-SHIELD-0005	8 - 10
	UNIVERSAL MESH FENCING BLACK FIXING CLIPS	ACCS-MSH-0001	7 - 9



	HEX HEAD BOLT M8 X 90mm	ACCS-GEN-0090	1
	M8 HEX NUT	API-SHIELD-0065	1
	60x60 BLACK RIBBED INSERTS	ACCS-RIB-0003	1

RapidShield® 1.8M - 3.0M High 868 Mesh Fencing System

A heavy-duty rapid deployment fencing solution offering increased strength and rigidity for demanding applications. The RapidShield® 868 Mesh system utilises twin-wire mesh panels, steel posts, ballast units, and security fixings to create a durable temporary perimeter.



Illustration	Description	Product Code	Quantity
	RAPIDSHIELD 1.8m - 3.0M HIGH INTERMEDIATE POST 60x60mm BOX WITH ELLIPSE HOLE	N/A	1
	RAPIDSHIELD® - UNIFOOT FULL ASSEMBLY	RAPID-UNIFOOT-1000	1
	1.8M - 3.0M HIGH X 2.5M WIDE 868 MESH FENCE PANEL ONLY	N/A	1
	Durablock Pre-Filled Ballast Block - 50kg	TEMP-BAL-0003	4
	M8 x 35MM STAR PROFILE SECURITY SCREW - STAINLESS STEEL	RAPI-SHIELD-0005	8 - 10
	868 MESH FENCING FIXING CLIPS	ACCS-MSH-0010	7 - 9

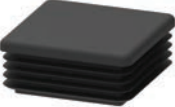

	HEX HEAD BOLT M8 X 90mm	ACCS-GEN-0090	1
	M8 HEX NUT	API-SHIELD-0065	1
	60x60 BLACK RIBBED INSERTS	ACCS-RIB-0003	1

RapidShield® 1.8m - 3.0m High 60x60 Corner Fencing Kit

Designed to create secure 90° corners within a RapidShield® perimeter, this corner fencing kit provides a stable and adaptable solution for changing site layouts. The system incorporates steel posts, ballast units, and security fixings to maintain perimeter integrity whilst allowing efficient installation and deployment.





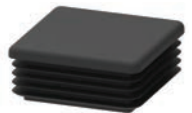



Illustration	Description	Product Code	Quantity
	1.8m - 3.0m HIGH BOLT DOWN 60X60 CORNER POST ONLY	N/A	1
	RAPIDSHIELD® - UNIFOOT FULL ASSEMBLY	RAPID-UNIFOOT-1000	1
	60x60 BLACK RIBBED INSERTS	ACCS-RIB-0003	2
	Durablock Pre-Filled Ballast Block - 50kg	TEMP-BAL-0003	4
	M8 x 35MM STAR PROFILE SECURITY SCREW - STAINLESS STEEL	RAPI-SHIELD-0005	15 - 19
	UNIVERSAL MESH FENCING BLACK FIXING CLIPS OR 868 MESH FENCING FIXING CLIPS	N/A	14 - 18
	RAPIDSHIELD 1.8m - 3.0M HIGH INTERMEDIATE POST 60x60mm BOX WITH ELLIPSE HOLE	N/A	1



	HEX HEAD BOLT M8 X 90mm	ACCS-GEN-0090	1
	M8 HEX NUT	API-SHIELD-0065	1

RapidShield® 1.8m - 3.0m High END POST KIT

Designed to provide a secure and professional termination point for a RapidShield® run. This complete end post kit includes the RapidShield® end post, base assembly, fixing brackets and all required fasteners for a safe and stable installation. Ideal for creating neat fence ends while maintaining system integrity and appearance.



Illustration	Description	Product Code	Quantity
	RAPIDSHIELD 1.8m - 3.0M HIGH INTERMEDIATE POST 60x60mm BOX WITH ELLIPSE HOLE	N/A	1
	RAPIDSHIELD® - UNIFOOT FULL ASSEMBLY	RAPID-UNIFOOT-1000	1
	60x60 BLACK RIBBED INSERTS	ACCS-RIB-0003	1
	Durablock Pre-Filled Ballast Block - 50kg	TEMP-BAL-0003	4
	M8 x 35MM STAR PROFILE SECURITY SCREW - STAINLESS STEEL	RAPI-SHIELD-0005	8 - 10
	UNIVERSAL MESH FENCING BLACK FIXING CLIPS OR 868 MESH FENCING FIXING CLIPS	N?A	7 - 9

	HEX HEAD BOLT M8 X 90mm	ACCS-GEN-0090	1
	M8 HEX NUT	API-SHIELD-0065	1

RapidShield® 2.0m - 2.4m High x 1.2m Wide Single Gate Kit

A secure access gate designed for integration within the RapidShield® fencing system. Providing controlled pedestrian access whilst maintaining perimeter security, the complete gate kit includes the gate leaf, posts, ballast units, gate hardware, and security fixings required for installation.



Illustration	Description	Product Code	Quantity
	RapidShield® 2.0M - 2.4M HIGH 60X60 868 MESH HINGE FRAME	N/A	1
	RapidShield® 2.0M - 2.4M HIGH 60X60 868 MESH CATCH FRAME	N/A	1
	ADAPTIGUARD 2.0M - 2.4M HIGH X 1.2M WIDE SLIDER GATE LEAF	N/A	1
	RAPIDSHIELD® - UNIFOOT FULL ASSEMBLY	RAPID-UNIFOOT-1000	2
	Durablock Pre-Filled Ballast Block - 50kg	TEMP-BAL-0003	8
	60x60 BLACK RIBBED INSERTS	ACCS-RIB-0003	4
	UNIVERSAL MESH FENCING BLACK FIXING CLIPS OR 868 MESH FENCING FIXING CLIPS	N/A	14 - 16



	M8 x 35MM STAR PROFILE SECURITY SCREW - STAINLESS STEEL	RAPI-SHIELD-0005	14 - 16
	40x40 BLACK RIBBED INSERTS	ACCS-RIB-0001	2
	ADJUSTABLE GATE EYE 150mm cw 20mm	ACCS-GEN-0001	2
	M5x20 ONEWAY PAN HEAD MC SCW A2	ACCS-GEN-0010	1
	M5 SHEAR NUT A2	ACCS-GEN-0015	1
	UNIVERSAL GATE DROP BOLT	ACCS-GEN-0101	1
	HEX HEAD BOLT M8 X 90mm - GALVANISED	ACCS-GEN-0090	2
	M8 HEX NUT	RAPI-SHIELD-0065	2

RapidShield® 2.0m - 2.4m x 4.0m Wide High Double Gate Kit

A robust access solution for RapidShield® perimeter installations. Designed to provide secure pedestrian and vehicle access without compromising perimeter integrity, the complete gate kit includes both gate leaves, posts, ballast units, gate hardware, and security fixings required for installation.



Illustration	Description	Product Code	Quantity
	RapidShield® 2.0M - 2.4M HIGH 60X60 868 MESH HINGE FRAME	N/A	2
	ADAPTIGUARD® 2.0M HIGH X 4.0M WIDE DL VEHICLE SITE GATE LEAFS	N/A	1
	RAPIDSHIELD® - UNIFOOT FULL ASSEMBLY	RAPID-UNIFOOT-1000	2
	Durablock Pre-Filled Ballast Block - 50kg	TEMP-BAL-0003	8
	60x60 BLACK RIBBED INSERTS	ACCS-RIB-0003	4
	UNIVERSAL MESH FENCING BLACK FIXING CLIPS OR 868 MESH FENCING FIXING CLIPS	N/A	14 - 16
	M8 x 35MM STAR PROFILE SECURITY SCREW - STAINLESS STEEL	RAPI-SHIELD-0005	14 - 16

	ADJUSTABLE GATE EYE 150mm cw 20mm	ACCS-GEN-0001	4
	HEX HEAD BOLT M8 X 90mm - GALVANISED	ACCS-GEN-0090	2
	M8 HEX NUT	RAPI-SHIELD-0065	2

## What is a RapidShield® Intermediate Fencing Kit?

A RapidShield® Intermediate Fencing Kit is a modular perimeter security solution designed for rapid deployment in temporary and semi-permanent applications. The system utilises rigid mesh panels, steel posts, ballast units, and security fixings to create a secure perimeter without the need for excavation or concrete foundations. Intermediate kits are used to form the main runs of fencing between corner, end, and gate assemblies.

### Key Features

**Rapid Deployment Design:** Enables quick installation and dismantling, making it ideal for construction sites, infrastructure projects, events, and temporary security applications.

**Modular System Configuration:** Designed to integrate seamlessly with RapidShield® corner kits, end kits, and gate assemblies to create flexible perimeter layouts.

**Secure Ballast Foundation:** Utilises the RapidShield® ballast system to provide stability and perimeter security without permanent ground works.

**Durable Steel Construction:** Manufactured from galvanised steel components for excellent corrosion resistance and long-term durability in demanding environments.

**Tamper-Resistant Fixings:** Supplied with security fixings to help maintain perimeter integrity and deter unauthorised removal of components.

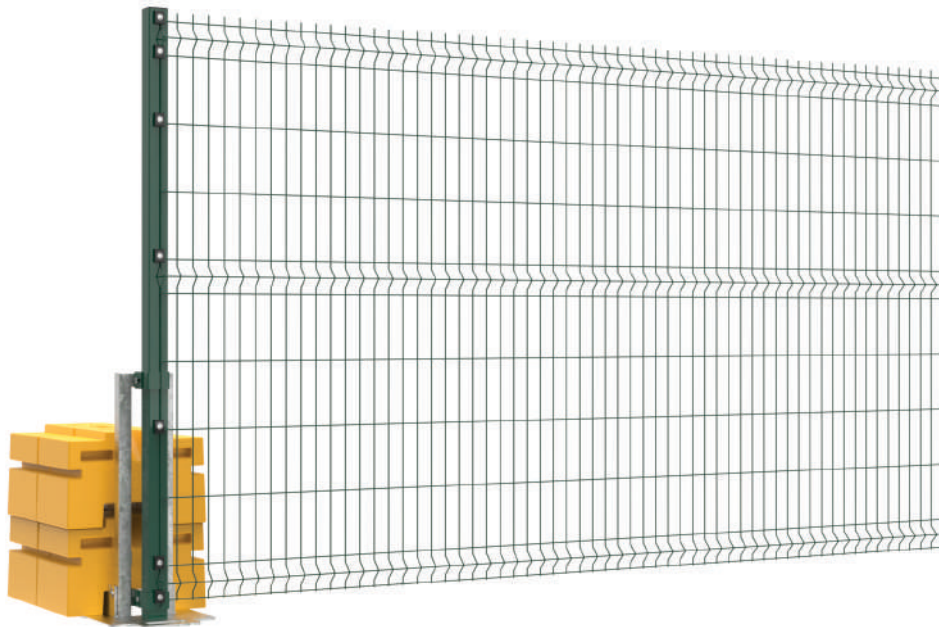

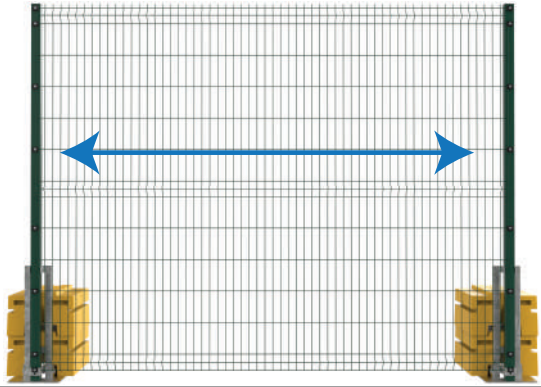

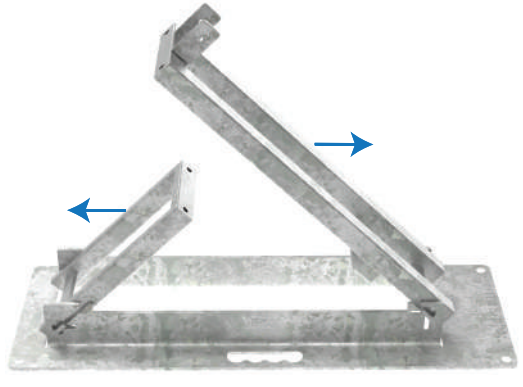

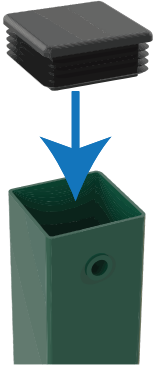
<b>1</b>	Using the technical drawing for your system, mark out the required post centres for the installation. Ensure each post position is aligned centrally with the UniFoot. A mesh panel may be used to confirm the correct spacing if required.
	
	

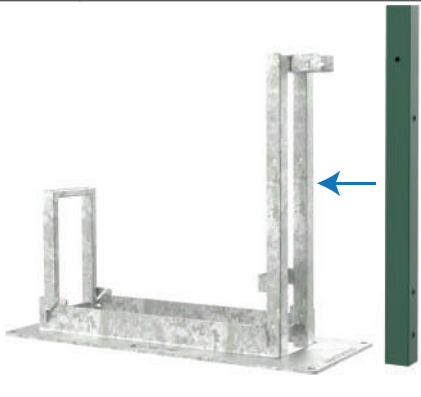
<b>2</b>	Place each RapidShield® UniFoot centrally on the marked-out spacing, ensuring it is straight, level, and correctly aligned with the fence line. Once positioned, unfold the front and rear support frames ready for assembly and lock into slots.
	
	

<b>3</b>	Insert the 60x60mm ribbed insert into the top of the intermediate post prior to installation.
	
	

<b>4</b>	Install the intermediate post into the RapidShield® UniFoot, ensuring the rivnuts face outwards and the through-hole aligns with the welded U-bracket on the front frame.
	
	

<b>5</b>	Install the M8 x 90mm hex head bolt through the welded U-bracket and post, then secure using the supplied M8 hex nut and tighten fully.
	
	

<b>6</b>	Install the bottom comb bracket onto the lower weld bar of the front frame. Use a spirit level to ensure the post is as plumb as possible before securing the bracket.
	
	





Note: Ensure all security fixings are fully tightened and shear nuts have been correctly installed before the system is put into service.

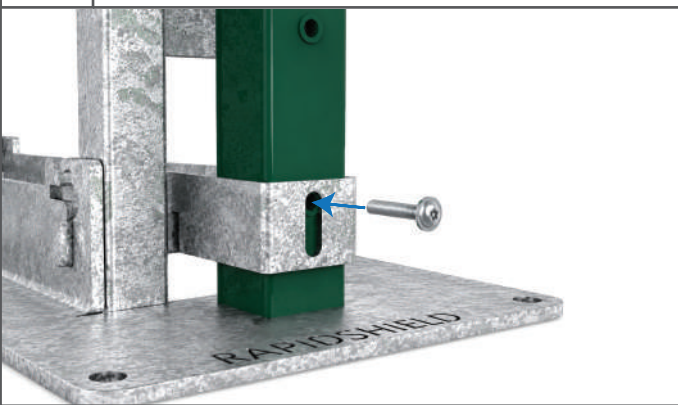



7	Install the bottom comb bracket security bolt through the bracket and into the rivnut to provide rigidity ready for panel installation.
	
	

8	Install the Durablocks onto the UniFoot, starting with the block against the front frame followed by the block against the rear frame until four blocks (200kg total ballast) have been installed.
	
	

9	Ensure all Durablocks are fully seated within the UniFoot locating grooves. Due to their weight, it is recommended that two people lift and position the blocks.
	
	

10	Position the chosen 358 Mesh, V Mesh, or 868 Mesh panel between the intermediate posts ready for clip installation.
	
	

11	Install the mesh clips, ensuring adequate ground clearance is maintained to achieve the correct panel position. 868 Mesh panels utilise larger clips to suit the increased wire diameter.
	
	

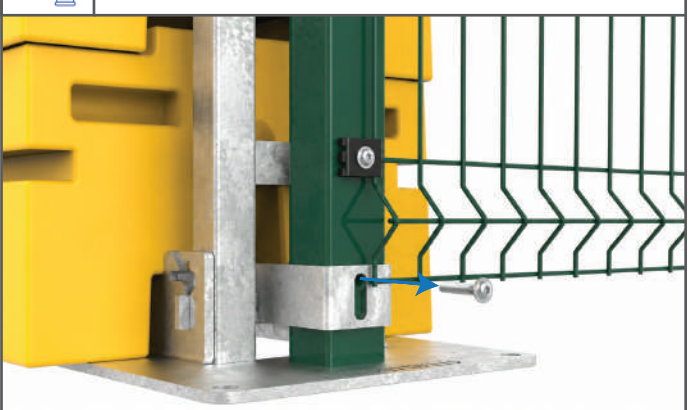
12	Remove the lower security fixing from the bottom comb bracket if required to allow installation of the final mesh clip.
	
	



Note: RapidShield® intermediate kits must be installed on suitably level and stable ground to ensure correct alignment and system performance.



**13** Install the final mesh clip and adjust the panel position if required. Ensure the fixing is fully tightened as this connection is critical to overall system rigidity.



**14** Repeat this process to create additional fencing runs. For longer installations, it may be beneficial to position and assemble multiple RapidShield® UniFoots before installing panels and fixings.



Note: Following installation, inspect all panels and posts to confirm they are correctly aligned and securely connected.



## What is a RapidShield® Corner Fencing Kit?

A RapidShield® Corner Fencing Kit is a modular perimeter security solution designed to create secure changes in direction within a RapidShield® fencing installation. The kit utilises steel posts, ballast units, and security fixings to form stable corner connections whilst maintaining the integrity of the perimeter. Corner kits are used to connect fencing runs and accommodate site layouts without the need for excavation or concrete foundations.

### Key Features

**Corner Formation:** Designed to create secure 90° changes in direction within a RapidShield® perimeter.

**Modular System Configuration:** Integrates seamlessly with RapidShield® intermediate, end, and gate kits to create flexible perimeter layouts.

**Secure Ballast Foundation:** Utilises the RapidShield® ballast system to provide stability and perimeter security without permanent ground works.

**Durable Steel Construction:** Manufactured from galvanised steel components for excellent corrosion resistance and long-term durability in demanding environments.

**Tamper-Resistant Fixings:** Supplied with security fixings to help maintain perimeter integrity and deter unauthorised removal of components.



**1** RapidShield® corner kits can be configured as either an inside corner or an outside corner. The primary differences are the panel positions and UniFoot location used to provide optimum corner stability.

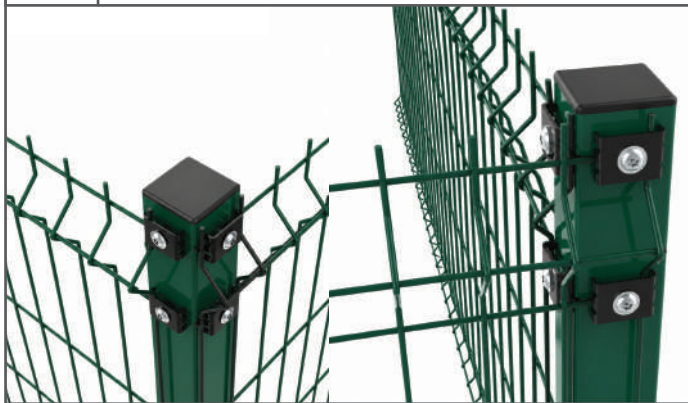

**2** Position the corner post between the intersecting mesh panels, ensuring both panels are square and the corner post is pushed firmly against the mesh.



**3** Install the mesh clips and security fixings to secure both panels to the corner post. 868 Mesh panels utilise larger clips to suit the increased wire diameter.

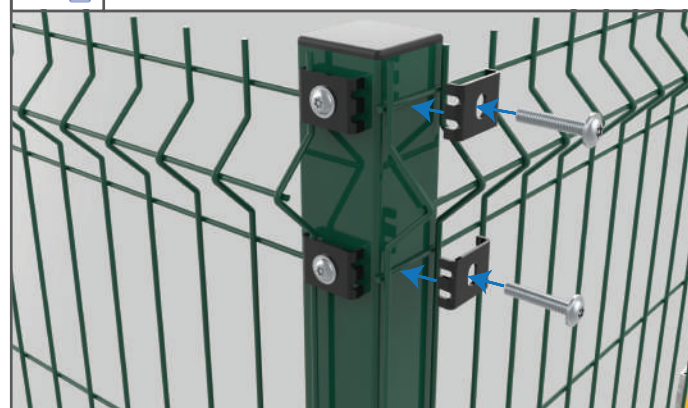

**4** On the inside of the chosen corner, position and unfold a RapidShield® UniFoot behind the mesh panels, ensuring the locking tabs are fully engaged.



**5** Install the intermediate post into the RapidShield® UniFoot, ensuring the rivnuts face outwards and the through-hole aligns with the welded U-bracket on the front frame.



**6** Install the M8 x 90mm hex head bolt through the welded U-bracket and post, then secure using the supplied M8 hex nut and tighten fully.

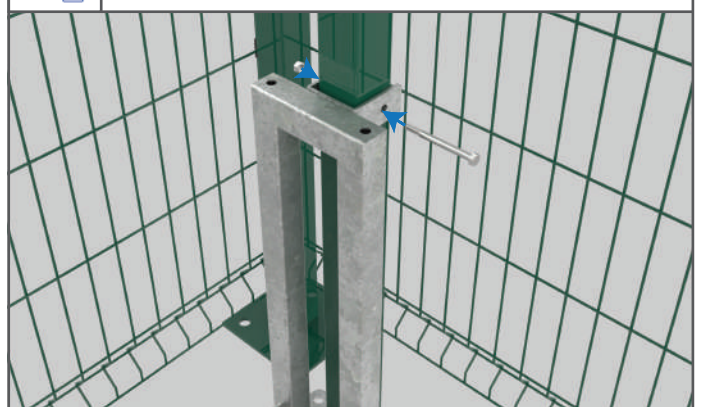

Note: Ensure corner assemblies are positioned correctly to maintain the intended perimeter layout and system stability.



**7** Install the bottom comb bracket onto the lower weld bar of the front frame. Use a spirit level to ensure the post is as plumb as possible before securing the bracket.



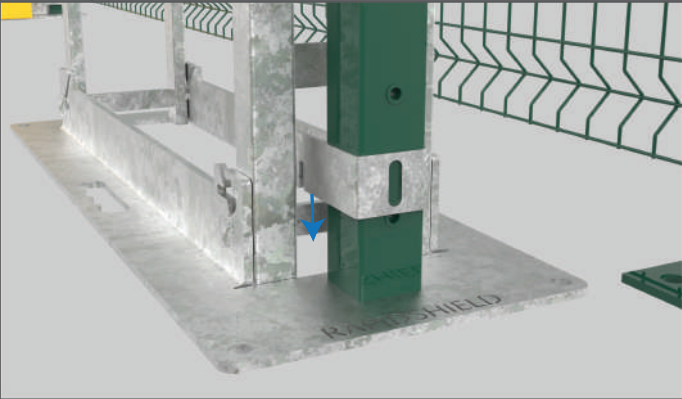

**8** Install the bottom comb bracket security bolt through the bracket and into the rivnut to provide rigidity ready for panel installation.







**9** Move the assembled UniFoot and post forward until the intermediate post intersects with the mesh panels meeting at the corner post.

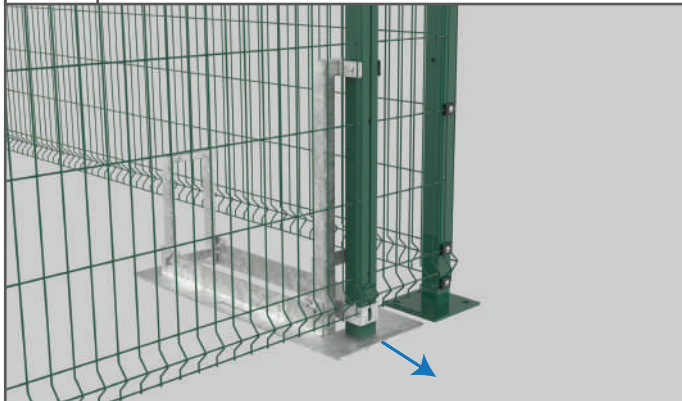



**10** Install the Durablocks onto the UniFoot, starting with the block against the front frame followed by the block against the rear frame until four blocks (200kg total ballast) have been installed.





**11** Ensure all Durablocks are fully seated within the UniFoot locating grooves. Due to their weight, it is recommended that two people lift and position the blocks.





**12** Install the mesh clips, ensuring adequate ground clearance is maintained to achieve the correct panel position. Remove the lower security fixing if required to allow installation of the final mesh clip.



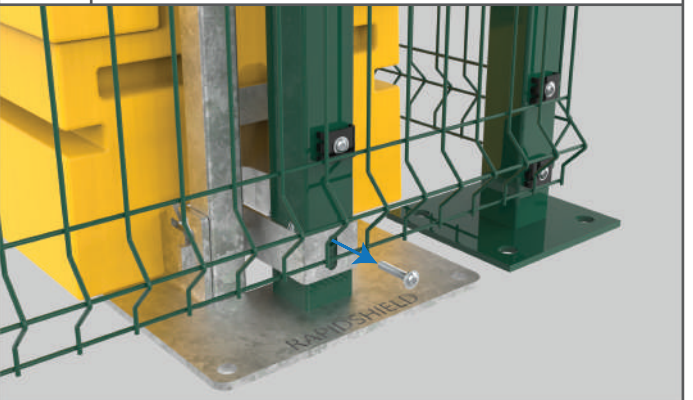



Note: All corner fixings must be securely tightened prior to installing adjacent fencing sections.

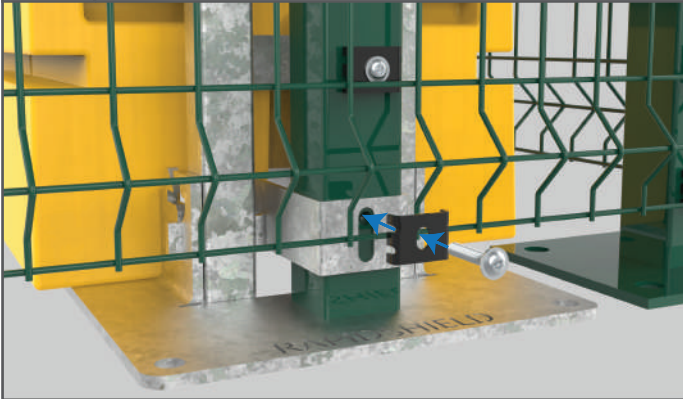

12

Install the final mesh clip and adjust the panel position if required. Ensure all fixings are fully tightened, as these connections are critical to overall system rigidity.



13

Where additional stability is required, particularly in exposed or high-wind environments, an additional RapidShield® intermediate bay may be installed on the adjoining side of the corner.



Note: Check that corner posts remain plumb throughout installation to prevent misalignment of connecting fence runs.



## What is a RapidShield® Single Gate Kit?

A RapidShield® Single Gate Kit is a modular access solution designed to provide secure pedestrian access within a RapidShield® fencing installation. The kit utilises a gate leaf, steel posts, ballast units, and security fixings to create a controlled access point whilst maintaining perimeter integrity. Single gate kits integrate seamlessly with RapidShield® fencing systems and require no excavation or concrete foundations.

### Key Features

**Controlled Access:** Provides a secure pedestrian access point within a RapidShield® perimeter.

**Modular System Configuration:** Integrates seamlessly with RapidShield® intermediate, corner, and end kits.

**Secure Ballast Foundation:** Utilises the RapidShield® ballast system to provide stability without permanent ground works.

**Durable Steel Construction:** Manufactured from galvanised steel components for excellent corrosion resistance and long-term durability.

**Tamper-Resistant Fixings:** Supplied with security fixings to help maintain perimeter integrity and deter unauthorised access.



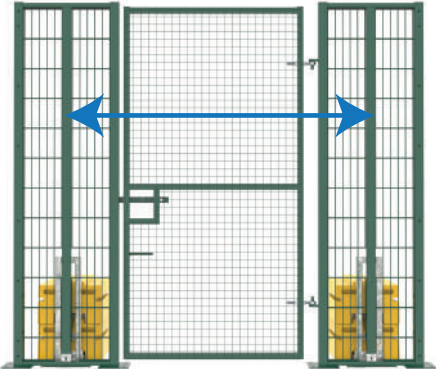

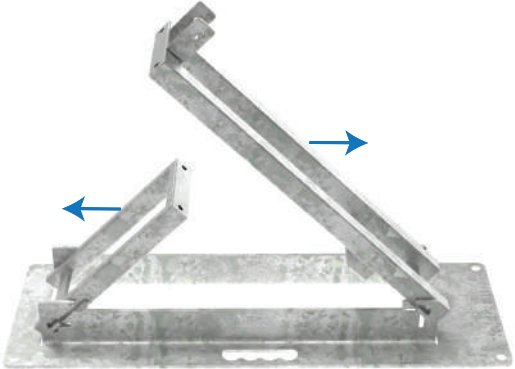

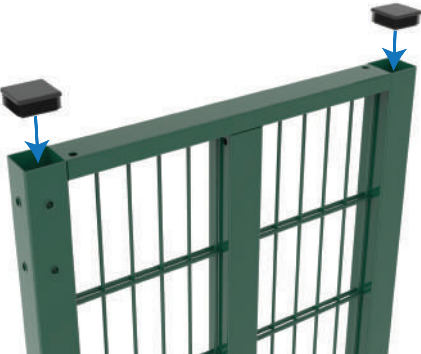
<b>1</b>	Using the technical drawing for your system, mark out the required post centres for the installation. Ensure each post position is aligned centrally with the RapidShield® UniFoot.
	
	

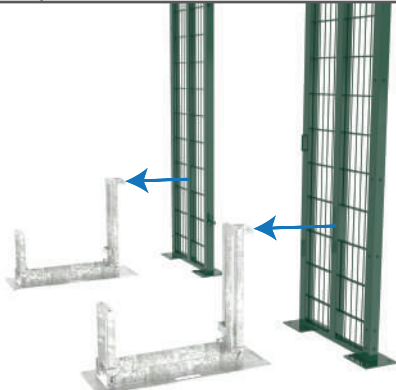
<b>2</b>	Place each RapidShield® UniFoot centrally on the marked-out spacing, ensuring it is straight, level, and correctly aligned with the fence line. Once positioned, unfold the front and rear support frames and engage the locking tabs.
	
	

<b>3</b>	Install the 60x60mm ribbed inserts into the top of both the hinge frame and catch frame prior to installation.
	
	

<b>4</b>	Position the hinge frame and catch frame onto their respective UniFoots. The catch frame should be installed on the left-hand UniFoot and the hinge frame on the right-hand UniFoot, ensuring both rivnut post sides faces outwards.
	
	

<b>5</b>	Install the M8 x 90mm hex head bolt through the welded U-bracket and frames, then secure using the supplied M8 hex nut and tighten fully.
	
	

<b>6</b>	Install the bottom comb bracket onto the lower weld bar of the front frame. Use a spirit level to ensure the frames are as plumb as possible before securing the bracket.
	
	





Note: Ensure the gate leaf can open and close freely without obstruction before final tightening of all fixings.

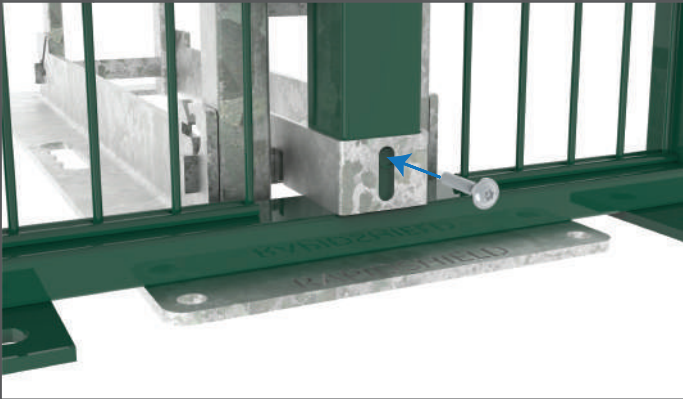

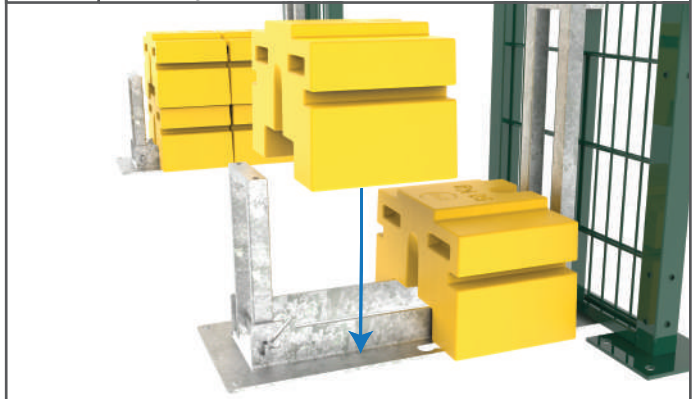

<b>7</b>	Install the bottom comb bracket security bolt through the comb bracket and into the rivnut to provide rigidity ready for gate installation.
	
	

<b>8</b>	Install the Durablocks onto each UniFoot, starting with the block against the front frame followed by the block against the rear frame until four blocks (200kg total ballast) have been installed on each assembly.
	
	

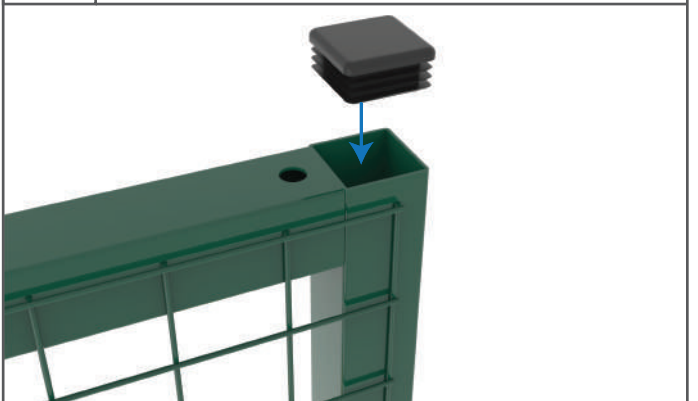
<b>9</b>	Ensure all Durablocks are fully seated within the UniFoot locating grooves. Due to their weight, it is recommended that two people lift and position the blocks.
	
	

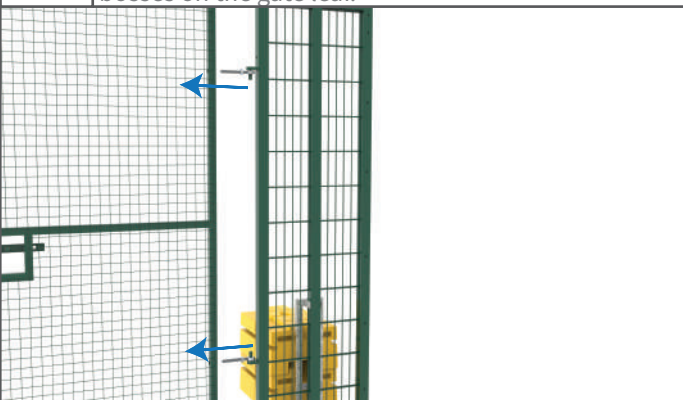
<b>10</b>	Install the 40x40mm ribbed inserts into the top of the gate leaf frame, where applicable, prior to gate installation.
	
	

<b>11</b>	Place the M20 x 200mm eyebolts onto the gate hooks with a single nut fitted to each eyebolt. With assistance, hold the gate leaf in position and insert the gate leaves through the eyebolts in the welded bosses on the gate leaf.
	
	

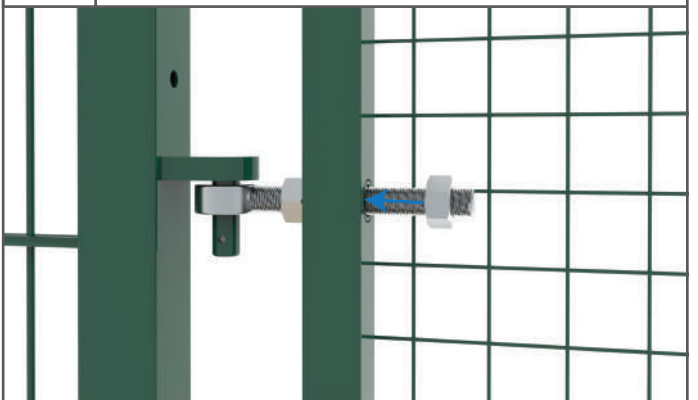
<b>12</b>	Once the eyebolts have been inserted through the bosses, install the remaining nuts and tighten. Adjust the eyebolts as required to achieve a consistent 50mm ground clearance.
	
	



Note: Gate posts must be installed plumb and securely fixed to ensure correct gate operation.



**13** Align the pre-welded gate slider with the receiver on the catch frame. Adjust the eyebolts if required and maintain an approximate 30mm gap between the gate leaf and catch frame.

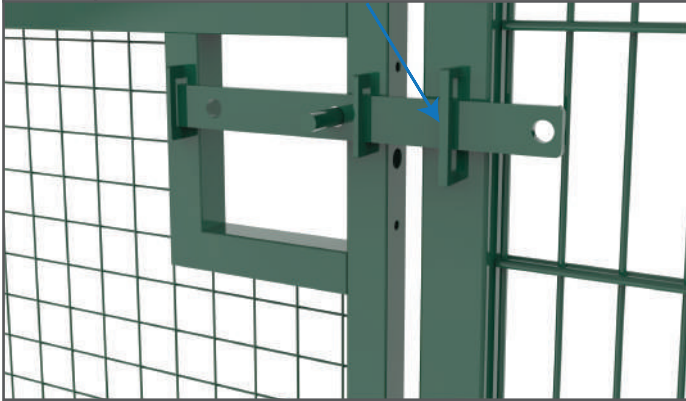

**14** Insert the supplied drop bolt into its holder ready for fixing. The drop bolt is intended to retain the gate in the open position only.

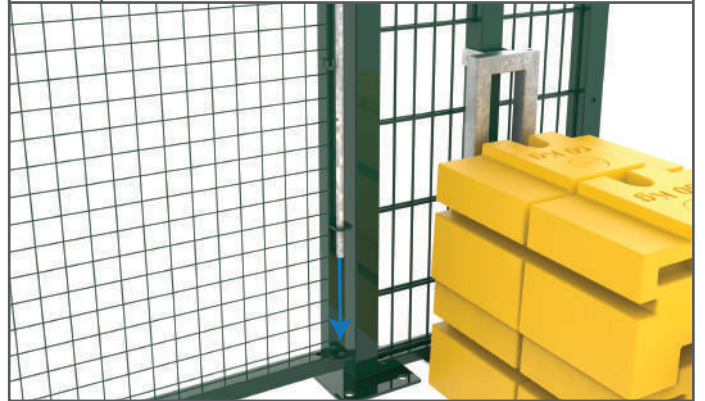

**15** Install the M5 x 20mm pan head bolt and M5 shear nut through the drop bolt holder assembly. Tighten the shear nut until the hex section shears off using a spanner or impact driver.

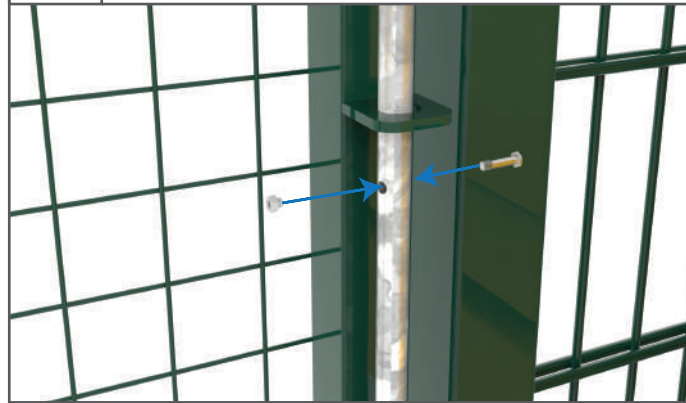

**16** The installation is now complete. Additional RapidShield® intermediate kits may be connected to the gate frames to create a run. Where additional rigidity is required, an end post kit can be installed between installed mesh panels.



**Note:** Following installation, verify all latching and locking mechanisms operate correctly and securely.



## What is a FirstFence Universal Padlockable Drop Bolt Kit?

The FirstFence Universal Padlockable Drop Bolt Kit is an essential security assembly designed to safely anchor and lock a manual gate leaf in place. It is specifically engineered to upgrade a standard heavy-duty drop bolt into a fully lockable system. By integrating a dedicated lock plate and an ergonomic handle, it allows groundskeepers to securely drop the bolt into its ground socket and lock it with a standard padlock. This prevents unauthorised access, tampering, or the accidental opening of machinery and maintenance gates in public spaces.

### Key Features

**Heavy-Duty Construction:** Built from robust pre-galvanised steel to withstand high-traffic use and resist corrosion in outdoor environments, ensuring the manual gate leaf remains securely anchored.

**Tamper-Resistant Fixing:** The core drop bolt assembly utilises M8 x 80mm galvanised cup head bolts paired with M8 snap-off security nuts, preventing unauthorised removal or tampering in public play areas.

**Padlockable Add-on Kit:** Transforms a standard drop bolt into a fully lockable system. The included PlaySecure Drop Bolt Lock Plate features a 21mm aperture designed to accommodate a sturdy padlock, securing the bolt in the 'down' position.

**Ergonomic Operation:** The assembly includes a dedicated PlaySecure Dropbolt Handle and a Universal Handle to make lifting and setting the heavy bolt easier and safer for authorised personnel.

**Complete Hardware Included:** Supplied with all necessary fixings, including the main bolt guide, fixture plate, anti-removal pin, and stainless steel bolts for the handle assembly, ensuring a complete and secure installation.



**1** Using the technical drawing for your system, mark out the required post centres for the installation. Ensure each post position is aligned centrally with the RapidShield® UniFoot.

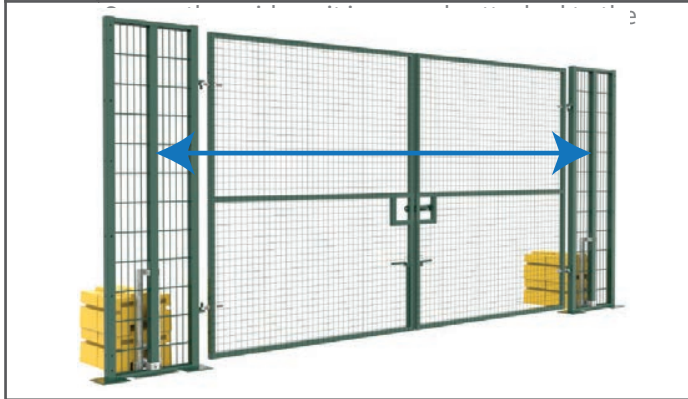

**2** Place each RapidShield® UniFoot centrally on the marked-out spacing, ensuring it is straight, level, and correctly aligned with the fence line. Once positioned, unfold the front and rear support frames and engage the locking tabs.

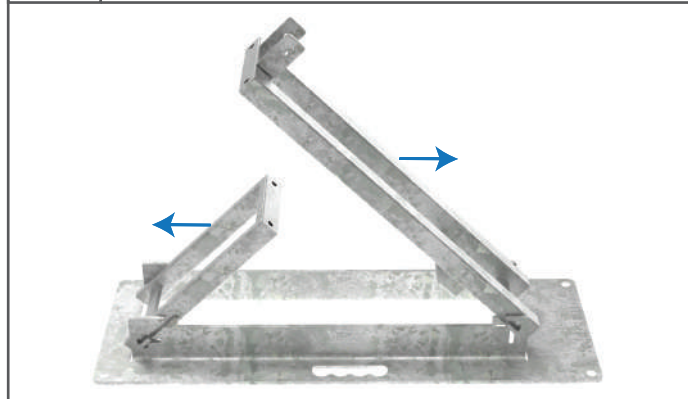

**3** Install the 60x60mm ribbed inserts into the top of both hinge frames prior to installation.



**4** Position the hinge frames onto their respective UniFoots, ensuring the rivnut faces point outwards and the gate hooks point towards each other. Make sure the hinge frames are positioned through the front frame u frames.

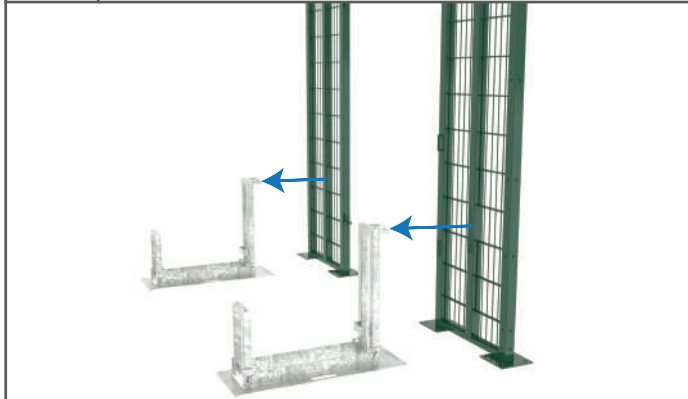

**5** Install the M8 x 90mm hex head bolt through the welded U-bracket and frame, then secure using the supplied M8 hex nut and tighten fully.



**6** Install the bottom comb bracket onto the lower weld bar of the front frame. Use a spirit level to ensure the frames are as plumb as possible before securing the bracket.

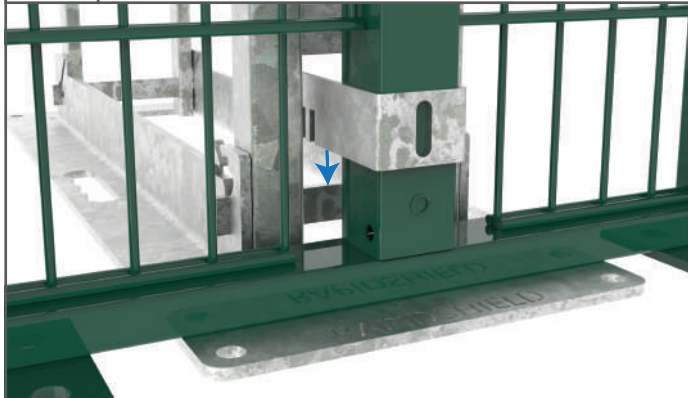

**Note:** Gate posts must remain plumb throughout installation to prevent excessive stress on hinges and locking components.



**7** Install the bottom comb brackets onto both hinge frames, then install the security bolt through the comb bracket and into the rivnut to provide rigidity ready for gate installation.



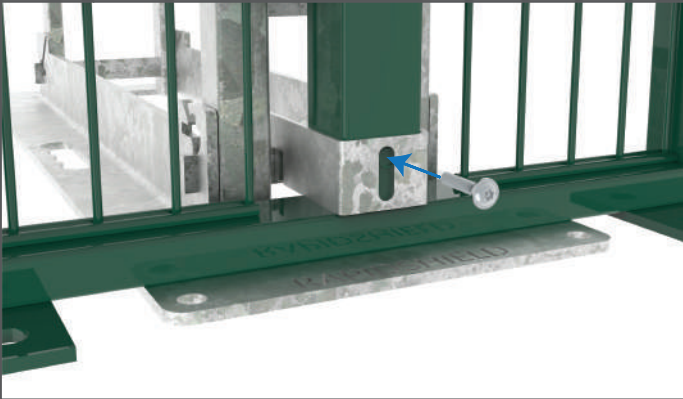

**8** Install the Durablocks onto each UniFoot, starting with the block against the front frame followed by the block against the rear frame until four blocks (200kg total ballast) have been installed on each assembly.



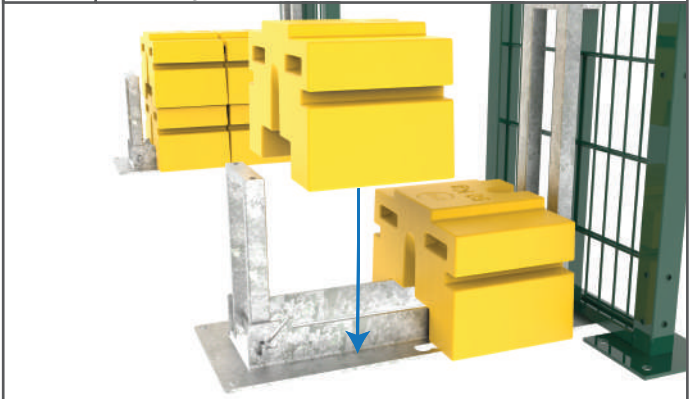

**9** Ensure all Durablocks are fully seated within the UniFoot locating grooves. Due to their weight, it is recommended that two people lift and position the blocks.







**10** Place the M20 x 200mm eyebolts onto the gate hooks with a single nut fitted to each eyebolt. With assistance, hold the gate leaves in position and insert through the eyebolts and through the welded bosses on the gate leaves.

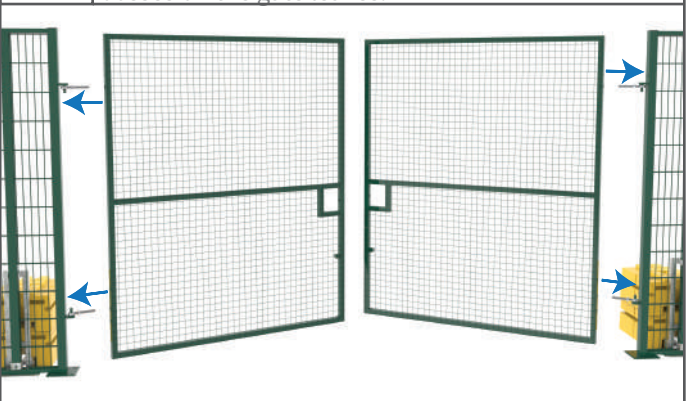



**11** Once the eyebolts have been inserted through the bosses, install the remaining nuts and tighten. Adjust the eyebolts as required to achieve a consistent 50mm ground clearance.





**12** Insert the supplied drop bolt into its holder ready for fixing. The drop bolt is intended to retain the gate in the open position. The drop bolt on the receiving leaf can also be used to secure the gate in the closed position.



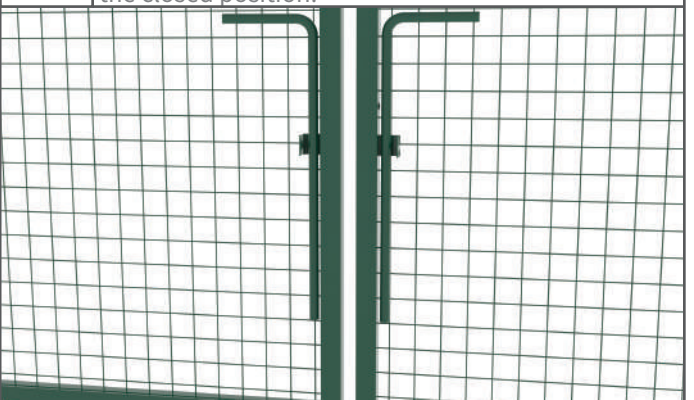



Note: Following installation, verify all drop bolts, latches, and locking mechanisms engage correctly before the gate is put into service.

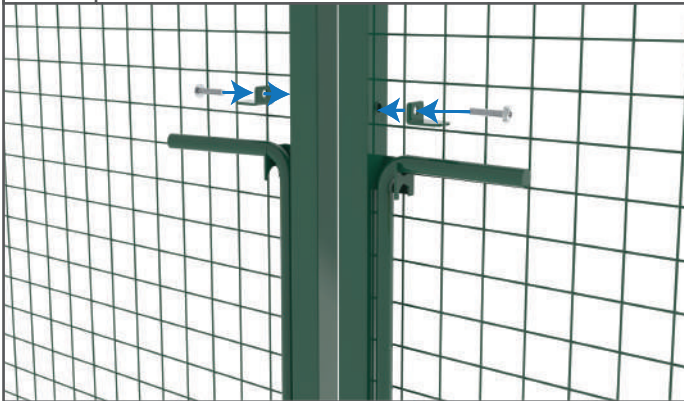

13

Install the M8 x 20mm socket head bolts through the drop bolt locking plates and into the rivnuts on the gate leaves. This prevents the drop bolts from being removed.



14

Install the slider through the slider leaf, ensuring it aligns with the receiver on the receiving leaf. Ensure the folded tab is orientated as shown in the installation image.

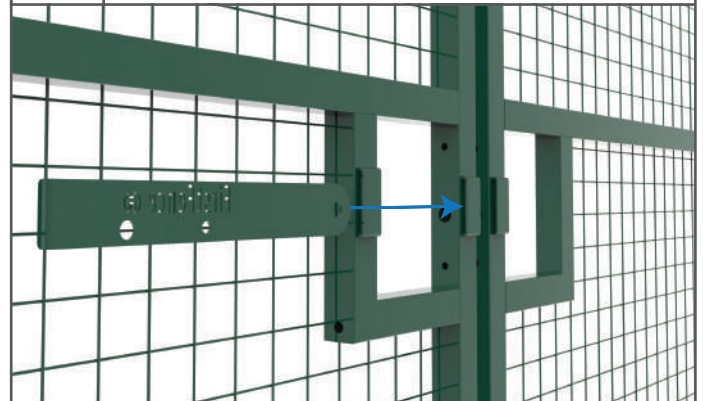

15

Insert the male handle through the front hole of the gate leaf and into the female handle on the rear of the slider. Twist the handles together to secure the slider in position.

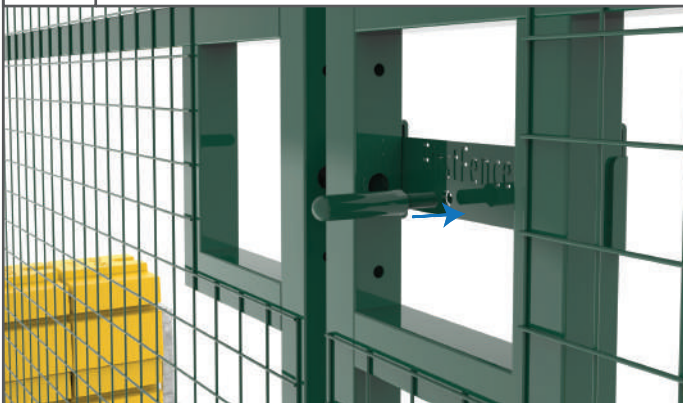

16

To prevent removal of the slider, install the grub screws into the female handle and tighten using the supplied Allen key. Adjust the gate eyebolts to maintain a 30mm gap and align the slider with the receiver.

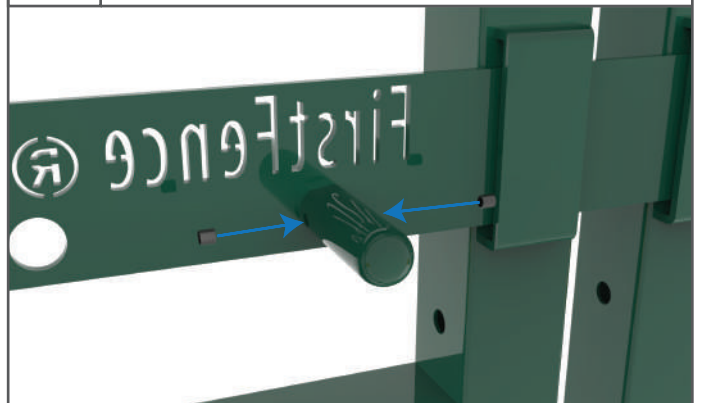

17

The installation is now complete. Additional RapidShield® intermediate kits may be connected to the gate frames to create a run. Where additional rigidity is required, an end post kit can be installed between installed mesh panels.



Note: Ensure both gate leaves are correctly aligned to achieve consistent operation and secure closing.



# 3.0 Installation Sign-Off Checklist

Action	Description	Consequence	Pass or Fail?	Remedial Action	Initial	Date
Ground Clearance Check	Ensure the system is installed on suitably level and stable ground.	Uneven ground may result in component misalignment and reduced system stability.		Re-position the system or relocate to a suitable installation area.		
Ballast Installation Check	Verify all ballast units are installed correctly and in the specified quantities.	Insufficient ballast may reduce system stability and compromise perimeter security.		Install the required ballast units in accordance with the installation instructions.		
Security Fixings Check	Confirm all security fixings have been installed and tightened correctly.	Missing or loose fixings may reduce perimeter integrity and allow unauthorised removal of components.		Install any missing fixings and tighten all connections as required.		
Panel & Post Alignment	Check all panels and posts are correctly aligned and securely connected.	Misaligned components may affect system performance and overall appearance.		Realign components and re-tighten all fixings before handover.		

**Sign Off Declaration:**

I hereby confirm that this product has been assembled and installed in accordance with the above requirements and any remedial works have been carried out before the final sign off:

Site Supervisor

Sign Off Date

Relationship to the Client

\_\_\_\_\_

\_\_\_\_\_

\_\_\_\_\_

Signature

\_\_\_\_\_



Note: This is an advisory best practice installation checklist to ensure your PlaySecure® hydraulic gates remain operational, effective, and safe.



## 4.0 Maintenance Schedule

Check Area	Result	Action
Ensure all panels, posts, and ballast units are free from excessive dirt, debris, or corrosion.	This will maintain the appearance and long-term performance of the RapidShield® system.	Remove debris and clean components using water and a non-abrasive cleaning method.
Check all security fixings, brackets, and connections remain secure and undamaged.	Loose or missing fixings may reduce perimeter integrity and system stability	Tighten or replace damaged or missing components as required.
Inspect panels and posts for signs of impact damage, bending, or misalignment.	Damaged components may affect system performance and perimeter security.	Replace damaged components and realign the system where necessary.
Verify ballast units remain correctly positioned and all components remain stable.	Incorrect ballast placement may compromise system stability and safety.	Reposition ballast units and inspect the installation in accordance with the assembly instructions.

### Take the hassle out of your maintenance schedule

First Fence Limited offers an annual inspection programme for your PlaySecure® System.

Contact our team today to include this quote onto your sales order.

[highsecuritymaintenance@firstfence.co.uk](mailto:highsecuritymaintenance@firstfence.co.uk)

### Operational Notes

1.0 The RapidShield® system is designed to provide a temporary or semi-permanent perimeter security solution. Additional loads such as climbing, attaching equipment, or fixing oversized signage may cause damage or reduce system stability.

2.0 All panels, posts, ballast units, brackets, and security fixings should be inspected regularly for wear, damage, corrosion, or misalignment. Replace damaged components as necessary to maintain system performance.

3.0 Any RapidShield® gate assemblies should be inspected regularly to ensure they operate correctly and remain securely fixed. Locks, hinges, and latching mechanisms should be maintained in good working order.

4.0 Following severe weather, impact events, or relocation of the system, a visual inspection should be carried out to confirm the installation remains secure, stable, and fit for purpose.